EMC Test Report

Report No.: AGC05443231045ER01

PRODUCT DESIGNATION : Wireless charger
BRAND NAME : N/A
MODEL NAME : M02184
APPLICANT : MID OCEAN BRANDS B.V
DATE OF ISSUE : Nov. 02, 2023
STANDARD(S) : ETSI EN 301 489-1 V2.2.3 (2019-11)
: ETSI EN 301489-3 V2.3.2 (2023-01)
REPORT VERSION : V1.0

Attestation of Global Compliance (Shenzhen) Co., Ltd



Any report having not been signed by authorized approver, or having been altered without authorization, or having not been stamped by the "Dedicated Testing/Inspection Stamp" is deemed to be invalid. Copying or excerpting portion of, or altering the content of the report is not permitted without the written authorization of AGC. The test results presented in the report apply only to the tested sample. Any objections to report issued by AGC should be submitted to AGC within 15days after the issuance of the test report. Further enquiry of validity or verification of the test report should be addressed to AGC by agc01@agccert.com.

Attestation of Global Compliance(Shenzhen)Co., Ltd
Attestation of Global Compliance(Shenzhen)Std & Tech Co., Ltd
Tel: +86-755 2523 4088 E-mail: agc@agccert.com Web: <http://www.agccert.com/>



REPORT REVISE RECORD

Report Version	Revise Time	Issued Date	Valid Version	Notes
V1.0	/	Nov. 02, 2023	Valid	Initial Release

Any report having not been signed by authorized approver, or having been altered without authorization, or having not been stamped by the “Dedicated Testing/Inspection Stamp” is deemed to be invalid. Copying or excerpting portion of, or altering the content of the report is not permitted without the written authorization of AGC. The test results presented in the report apply only to the tested sample. Any objections to report issued by AGC should be submitted to AGC within 15days after the issuance of the test report. Further enquiry of validity or verification of the test report should be addressed to AGC by agc01@agccert.com.

Attestation of Global Compliance(Shenzhen)Co., Ltd
Attestation of Global Compliance(Shenzhen)Std & Tech Co., Ltd
Tel: +86-755 2523 4088 E-mail: agc@agccert.com Web: <http://www.agccert.com/>

TABLE OF CONTENTS

1. TEST REPORT CERTIFICATION 6

2. GENERAL INFORMATION 7

 2.1. DESCRIPTION OF EUT 7

 2.2. OBJECTIVE 7

 2.3. TEST STANDARDS AND RESULTS 7

 2.4. TEST ITEMS AND THE RESULTS 8

 2.5. ENVIRONMENTAL CONDITIONS 8

3. TEST MODE DESCRIPTION 9

4. MEASUREMENT UNCERTAINTY 10

5. SUPPORT EQUIPMENT 11

6. IDENTIFICATION OF THE RESPONSIBLE TESTING LOCATION 12

7. RADIATED DISTURBANCE MEASUREMENT 14

 7.1. LIMITS OF RADIATED DISTURBANCES 14

 7.2. TEST PROCEDURE 14

 7.3. BLOCK DIAGRAM OF TEST SETUP 15

 7.4 TEST RESULT 16

8. MAINS TERMINAL DISTURBANCE VOLTAGE MEASUREMENT 18

 8.1. LIMITS OF MAINS TERMINAL DISTURBANCE VOLTAGE 18

 8.2. TEST PROCEDURE 18

 8.3. TEST SETUP 18

 8.4. TEST RESULT 19

9. HARMONIC CURRENT MEASUREMENT 21

 9.1. LIMITS OF HARMONIC CURRENT 21

 9.2. TEST PROCEDURE 21

 9.3. TEST SETUP 22

 9.4. TEST RESULT 22

10. VOLTAGE FLUCTUATIONS AND FLICK MEASUREMENT 23

 10.1. LIMITS OF VOLTAGE FLUCTUATIONS AND FLICK 23

 10.2. TEST PROCEDURE 23

 10.3. TEST SETUP 23

 10.4. TEST RESULT 23

11. IMMUNITY TEST 24

 11.1. DESCRIPTION OF PERFORMANCE CRITERIA 24

 11.2. GENERAL PERFORMANCE CRITERIA 24

12. ELECTROSTATIC DISCHARGE IMMUNITY TEST 26

Any report having not been signed by authorized approver, or having been altered without authorization, or having not been stamped by the “Dedicated Testing/Inspection Stamp” is deemed to be invalid. Copying or excerpting portion of, or altering the content of the report is not permitted without the written authorization of AGC. The test results presented in the report apply only to the tested sample. Any objections to report issued by AGC should be submitted to AGC within 15days after the issuance of the test report. Further enquiry of validity or verification of the test report should be addressed to AGC by agc01@agccert.com.

12.1. TEST SPECIFICATION	26
12.2. TEST PROCEDURE	26
12.3. TEST SETUP	27
12.4. TEST RESULT	29
12.5. PERFORMANCE	29
13. RADIATED, RADIO FREQUENCY ELECTROMAGNETIC FIELD IMMUNITY TEST	30
13.1. TEST SPECIFICATION	30
13.2. TEST PROCEDURE	30
13.3. TEST SETUP	31
13.4. TEST RESULT	32
13.5. PERFORMANCE	32
14. ELECTRICAL FAST TRANSIENT/BURST IMMUNITY TEST	33
14.1. TEST SPECIFICATION	33
14.2. TEST PROCEDURE	33
14.3. TEST SETUP	33
14.4. TEST RESULT	34
14.5. PERFORMANCE	34
15. SURGE IMMUNITY TEST	35
15.1. TEST SPECIFICATION	35
15.2. TEST PROCEDURE	35
15.3. TEST SETUP	35
15.4. TEST RESULT	36
15.5. PERFORMANCE	36
16. IMMUNITY TO CONDUCTED DISTURBANCES INDUCED BY RF FIELDS	37
16.1. TEST SPECIFICATION	37
16.2. TEST PROCEDURE	37
16.3. TEST SETUP	37
16.4. TEST RESULT	38
16.5. PERFORMANCE	38
17. VOLTAGE DIPS AND SHORT INTERRUPTIONS IMMUNITY TEST	39
17.1. TEST SPECIFICATION	39
17.2. TEST PROCEDURE	39
17.3. TEST SETUP	39
17.4. TEST RESULT	40
17.5. PERFORMANCE	40
APPENDIX I: PHOTOGRAPHS OF TEST SETUP	41

Any report having not been signed by authorized approver, or having been altered without authorization, or having not been stamped by the “Dedicated Testing/Inspection Stamp” is deemed to be invalid. Copying or excerpting portion of, or altering the content of the report is not permitted without the written authorization of AGC. The test results presented in the report apply only to the tested sample. Any objections to report issued by AGC should be submitted to AGC within 15days after the issuance of the test report. Further enquiry of validity or verification of the test report should be addressed to AGC by agc01@agccert.com.

APPENDIX II: PHOTOGRAPHS OF THE EUT 45

Any report having not been signed by authorized approver, or having been altered without authorization, or having not been stamped by the “Dedicated Testing/Inspection Stamp” is deemed to be invalid. Copying or excerpting portion of, or altering the content of the report is not permitted without the written authorization of AGC. The test results presented in the report apply only to the tested sample. Any objections to report issued by AGC should be submitted to AGC within 15days after the issuance of the test report. Further enquiry of validity or verification of the test report should be addressed to AGC by agc01@agccert.com.

Attestation of Global Compliance(Shenzhen)Co., Ltd
Attestation of Global Compliance(Shenzhen)Std & Tech Co., Ltd
Tel: +86-755 2523 4088 E-mail: agc@agccert.com Web: <http://www.agccert.com/>

1. TEST REPORT CERTIFICATION

Applicant	MID OCEAN BRANDS B.V
Address	7/F, Kings Tower, 111 King Lam Street, Cheung Sha Wan, Kowloon, Hong Kong.
Manufacturer	MID OCEAN BRANDS B.V
Address	7/F, Kings Tower, 111 King Lam Street, Cheung Sha Wan, Kowloon, Hong Kong.
Factory	MID OCEAN BRANDS B.V
Address	7/F, Kings Tower, 111 King Lam Street, Cheung Sha Wan, Kowloon, Hong Kong.
Product Designation	Wireless charger
Brand Name	N/A
Test Model	MO2184
Series Model(s)	N/A
Difference Description	N/A
Date of receipt of test item	Oct. 27, 2023
Date of test	Oct. 27, 2023 to Nov. 02, 2023
Deviation	None
Condition of Test Sample	Normal
Test Result	Pass
Report Template	AGCRT-EC-EMC

Note: The test results of this report relate only to the tested sample identified in this report.

Prepared By 

 Cici Li
 (Project Engineer) Nov. 02, 2023

Reviewed By 

 Calvin Liu
 (Reviewer) Nov. 02, 2023

Approved By 

 Max Zhang
 (Authorized Officer) Nov. 02, 2023

Any report having not been signed by authorized approver, or having been altered without authorization, or having not been stamped by the “Dedicated Testing/Inspection Stamp” is deemed to be invalid. Copying or excerpting portion of, or altering the content of the report is not permitted without the written authorization of AGC. The test results presented in the report apply only to the tested sample. Any objections to report issued by AGC should be submitted to AGC within 15days after the issuance of the test report. Further enquiry of validity or verification of the test report should be addressed to AGC by agc01@agccert.com.

2. GENERAL INFORMATION

2.1. DESCRIPTION OF EUT

Details of technical specification refer to the description in follows:

Operating Frequency	110KHz-205KHz
Hardware Version	V1.0
Software Version	V1.0
Antenna Type	Coil Antenna
Power Supply	Input:DC 5V/2A, 9V/2A Wireless Output:DC 5V/1A, 7.5V/1A, 9V/1.1A, 9V/1.67A
Wireless Charging Output Power	5W/7.5W/10W/15W(max 15W)

2.2. OBJECTIVE

Perform Electro Magnetic Interference (EMI) and Electro Magnetic Susceptibility (EMS) tests for CE Marking.

2.3. TEST STANDARDS AND RESULTS

The EUT has been tested according to ETSI EN 301 489-1 V2.2.3 (2019-11) and ETSI EN 301489-3 V2.3.2 (2023-01).

ETSI EN 301 489-1	ElectroMagnetic Compatibility (EMC) standard for radio equipment and services; Part 1: Common technical requirements; Harmonised Standard for ElectroMagnetic Compatibility.
ETSI EN 301 489-3	Electro Magnetic Compatibility (EMC) standard for radio equipment and services; Part 3: Specific conditions for Short-Range Devices (SRD) operating on frequencies between 9 kHz and 246 GHz; Harmonised Standard covering the essential requirements of article 3.1(b) of Directive 2014/53/EU

Any report having not been signed by authorized approver, or having been altered without authorization, or having not been stamped by the "Dedicated Testing/Inspection Stamp" is deemed to be invalid. Copying or excerpting portion of, or altering the content of the report is not permitted without the written authorization of AGC. The test results presented in the report apply only to the tested sample. Any objections to report issued by AGC should be submitted to AGC within 15days after the issuance of the test report. Further enquiry of validity or verification of the test report should be addressed to AGC by agc01@agccert.com.

2.4. TEST ITEMS AND THE RESULTS

No.	Basic Standard	Test Type	Result
EMISSION (EN 301 489-1 §7.1)			
1	EN 55032	Radiated emission	PASS
2	EN 55032	Conducted emission, AC ports	PASS
3	EN 55032	Conducted emission, Telecom ports	N/A
4	EN 61000-3-2	Harmonic current emissions	PASS
5	EN 61000-3-3	Voltage fluctuations & flicker	PASS
IMMUNITY (EN 301 489-1 §7.2)			
6	EN 61000-4-2	Electrostatic discharge immunity	PASS
7	EN 61000-4-3	Radiated RF electromagnetic field immunity	PASS
8	EN 61000-4-4	Electrical fast transient/burst immunity	PASS
9	ISO 7637-1, -2	Transients and surges, DC ports	N/A
10	EN 61000-4-5	Surge immunity, AC ports	PASS
11	EN 61000-4-6	Immunity to conducted disturbances induced by RF fields	PASS
12	EN 61000-4-11	Voltage dips and short interruptions immunity	PASS

Note: 1. N/A- Not Applicable.
2. The latest versions of basic standards are applied.

2.5. ENVIRONMENTAL CONDITIONS

During the measurement the environmental conditions were within the listed ranges:

- Temperature: 15-35°C
- Relative humidity: 30-60%
- Atmospheric pressure: 86-106kPa

Any report having not been signed by authorized approver, or having been altered without authorization, or having not been stamped by the "Dedicated Testing/Inspection Stamp" is deemed to be invalid. Copying or excerpting portion of, or altering the content of the report is not permitted without the written authorization of AGC. The test results presented in the report apply only to the tested sample. Any objections to report issued by AGC should be submitted to AGC within 15days after the issuance of the test report. Further enquiry of validity or verification of the test report should be addressed to AGC by agc01@agccert.com.

Attestation of Global Compliance(Shenzhen)Co., Ltd
Attestation of Global Compliance(Shenzhen)Std & Tech Co., Ltd
Tel: +86-755 2523 4088 E-mail: agc@agccert.com Web: http://www.agccert.com/

3. TEST MODE DESCRIPTION

TEST MODE DESCRIPTION		
NO.	EMI TEST MODE DESCRIPTION	WORST
1	Wireless Full Load Mode	V
2	Wireless Half Load Mode	--
3	Wireless Null Load Mode	--
NO.	EMS TEST MODE DESCRIPTION	WORST
1	Wireless Full Load Mode	V
2	Wireless Half Load Mode	--
3	Wireless Null Load Mode	--

Note: 1. V means EMI worst mode.
2. All modes have been tested and only the worst mode test data recorded in the test report.

I/O Port Information (Applicable Not Applicable)

I/O Port of EUT			
I/O Port Type	Number	Cable Description	Tested With
Type-C Port	1	0.25m unshielded	1

Any report having not been signed by authorized approver, or having been altered without authorization, or having not been stamped by the "Dedicated Testing/Inspection Stamp" is deemed to be invalid. Copying or excerpting portion of, or altering the content of the report is not permitted without the written authorization of AGC. The test results presented in the report apply only to the tested sample. Any objections to report issued by AGC should be submitted to AGC within 15days after the issuance of the test report. Further enquiry of validity or verification of the test report should be addressed to AGC by agc01@agccert.com.

4. MEASUREMENT UNCERTAINTY

The uncertainty is calculated using the methods suggested in the “Guide to the Expression of Uncertainty in measurement” (GUM) published by CISPR and ANSI.

- Uncertainty of Conducted Emission, $U_c = \pm 2.9\text{dB}$
- Uncertainty of Radiated Emission below 1GHz, $U_c = \pm 3.9\text{dB}$
- Uncertainty of Radiated Emission above 1GHz, $U_c = \pm 4.9\text{ dB}$

Any report having not been signed by authorized approver, or having been altered without authorization, or having not been stamped by the “Dedicated Testing/Inspection Stamp” is deemed to be invalid. Copying or excerpting portion of, or altering the content of the report is not permitted without the written authorization of AGC. The test results presented in the report apply only to the tested sample. Any objections to report issued by AGC should be submitted to AGC within 15days after the issuance of the test report. Further enquiry of validity or verification of the test report should be addressed to AGC by agc01@agccert.com.

Attestation of Global Compliance(Shenzhen)Co., Ltd
Attestation of Global Compliance(Shenzhen)Std & Tech Co., Ltd
Tel: +86-755 2523 4088 E-mail: agc@agccert.com Web: <http://www.agccert.com/>

5. SUPPORT EQUIPMENT

Product Name	Manufacturer	Model	Mains cable	Signal cable	Specifications
wireless charging load	Huawei	N/A	--	--	Support 5W,7.5W,10W,15W
Adapter	jinbaotong	K-T10E0502000E	--	--	AC100-240V,50-60 Hz,0.35A,DC5V/2A

Note: All the above equipment/cables were placed in worse case positions to maximize emission signals during emission test.

6. IDENTIFICATION OF THE RESPONSIBLE TESTING LOCATION

Site	Attestation of Global Compliance (Shenzhen) Co., Ltd
Location	1-2/F, Building 19, Junfeng Industrial Park, Chongqing Road, Heping Community, Fuhai Street, Bao'an District, Shenzhen, Guangdong, China

TEST EQUIPMENT OF CONDUCTED EMISSION TEST

Equipment	Manufacturer	Model	S/N	Cal. Date	Cal. Due
Test Receiver	R&S	ESPI	101206	Jun. 03, 2023	Jun. 02, 2024
Artificial power network	R&S	ESH2-Z5	100086	Jun. 03, 2023	Jun. 02, 2024
Test Software	R&S	V1.71	N/A	N/A	N/A

TEST EQUIPMENT OF RADIATED EMISSION TEST

Equipment	Manufacturer	Model	S/N	Cal. Date	Cal. Due
Test Receiver	RS	ESCI	10096	Feb. 18, 2023	Feb. 17, 2024
Wideband Antenna	SCHWARZBEC K	VULB9168	D69250	May 11, 2023	May 10, 2025
Test software	FARA	V.RA-03A	N/A	N/A	N/A

TEST EQUIPMENT OF POWER HARMONICS / VOLTAGE FLUCTUATION / FLICKER TEST

Equipment	Manufacturer	Model	S/N	Cal. Date	Cal. Due
Signal Conditioning Unit	Schaffner	CCN1000-1	72431	Jun. 08, 2023	Jun. 07, 2024
AC Source	Schaffner	NSG 1007	56825	Jun. 02, 2023	Jun. 01, 2024
Test Software	TC	4.29.0	N/A	N/A	N/A

TEST EQUIPMENT OF ESD TEST

Equipment	Manufacturer	Model	S/N	Cal. Date	Cal. Due
ESD Simulator	Schaffner	NSG 438	782	Dec. 30, 2022	Dec. 29, 2023

Any report having not been signed by authorized approver, or having been altered without authorization, or having not been stamped by the "Dedicated Testing/Inspection Stamp" is deemed to be invalid. Copying or excerpting portion of, or altering the content of the report is not permitted without the written authorization of AGC. The test results presented in the report apply only to the tested sample. Any objections to report issued by AGC should be submitted to AGC within 15days after the issuance of the test report. Further enquiry of validity or verification of the test report should be addressed to AGC by agc01@agccert.com.

TEST EQUIPMENT OF SURGE/EFT/DIPS TEST

Equipment	Manufacturer	Model	S/N	Cal. Date	Cal. Due
Lightning Surge/EFT/DIPS Generator	Schaffner	Modula 6150	34437	Jun. 08, 2023	Jun. 07, 2024
Test Software	TC	2.31	N/A	N/A	N/A

TEST EQUIPMENT OF RS IMMUNITY TEST

Equipment	Manufacturer	Model	S/N	Cal. Date	Cal. Due
Signal Generator	Aglient	N5182A	MY50140530	Feb.17, 2023	Feb.16, 2024
Directional coupler	Werlatone	C5571-10	99463	Mar. 10, 2022	Mar. 09, 2024
Directional coupler	Werlatone	C5571-10	99482	Mar. 10, 2022	Mar. 09, 2024
Power Meter	R&S	NRVD	8323781027	Mar. 24, 2023	Mar. 23, 2025
Power Amplifier	KALMUS	7100LC	04-02/17-06-001	N/A	N/A
Power Amplifier	Milmega	AS0104-55_55	1004793	N/A	N/A
Power amplifier	rflight	NTWPA-2560100	17063183	N/A	N/A
Biconilog Antenna	ETS	3142C	00060447	N/A	N/A
Broadband High Gain Horn Antenna	SCHWARZBECK	BBHA 9120 J	00073	N/A	N/A
Test Software	Tonscend	2.0.1.8	N/A	N/A	N/A

TEST EQUIPMENT OF CS IMMUNITY TEST

Equipment	Manufacturer	Model	S/N	Cal. Date	Cal. Due
Power amplifier	AR	75A250	18464	N/A	N/A
CDN	KNORR	T4-1	10215	Jun. 02, 2023	Jun. 01, 2025
6dB attenuator	ZHINAN	E-002	N/A	Aug. 04, 2022	Aug. 03, 2024
Power Probe	R&S	URV5-Z4	100124	Mar. 24, 2023	Mar. 23, 2025
Power Meter	R&S	NRVD	8323781027	Mar. 24, 2023	Mar. 23, 2025
Signal Generator	Aglient	E4421B	MY43351603	Feb. 17, 2023	Feb. 16, 2024
Directional coupler	Werlatone	C5571-10	99463	Mar. 10, 2022	Mar. 09, 2024
Test Software	Tonscend	2.0.1.7	N/A	N/A	N/A

Any report having not been signed by authorized approver, or having been altered without authorization, or having not been stamped by the “Dedicated Testing/Inspection Stamp” is deemed to be invalid. Copying or excerpting portion of, or altering the content of the report is not permitted without the written authorization of AGC. The test results presented in the report apply only to the tested sample. Any objections to report issued by AGC should be submitted to AGC within 15days after the issuance of the test report. Further enquiry of validity or verification of the test report should be addressed to AGC by agc01@agccert.com.

7. RADIATED DISTURBANCE MEASUREMENT

7.1. LIMITS OF RADIATED DISTURBANCES

Limits for radiated disturbance 30M to1 GHz at a measurement distance of 3 m

Frequency range (MHz)	Quasi peak limits(dBuV/m), for Class B ITE, at 3m measurement distance
30-230	40
230-1000	47

Note: 1. The lower limit shall apply at the transition frequency.
2. Additional provisions may be required for cases where interference occurs.

7.2. TEST PROCEDURE

- (1). The EUT was placed on the top of an insulating table 0.8 meters above the ground at a semi-anechoic chamber. The table was rotated 360 degrees to determine the position of the highest radiation.
- (2). The EUT was set 3 meters away from the interference-receiving antenna, which was mounted on the top of a variable-height antenna tower.
- (3).The antenna is a broadband antenna, and its height is varied from 1 to 4 meter above the ground to determine the maximum value of the field strength. Both horizontal and vertical polarizations of the antenna are set to make the measurement.
- (4). For each suspected emission, the EUT was arranged to its worst case and then the antenna was tuned to the heights from 1 to 4 meters and the ratable table was turned from 0 degrees to 360 degrees to find the maximum reading.
- (5).The test-receiver system was set to Peak Detector Function and Specified Bandwidth with Maximum Hold Mode. If the emission level of the EUT in peak mode was 10dB lower than the limit specified, then testing could be stopped and the peak values of the EUT would be reported. Otherwise the emission that did not have 10dB margin would be retested one by one using the quasi-peak method.

Any report having not been signed by authorized approver, or having been altered without authorization, or having not been stamped by the "Dedicated Testing/Inspection Stamp" is deemed to be invalid. Copying or excerpting portion of, or altering the content of the report is not permitted without the written authorization of AGC. The test results presented in the report apply only to the tested sample. Any objections to report issued by AGC should be submitted to AGC within 15days after the issuance of the test report. Further enquiry of validity or verification of the test report should be addressed to AGC by agc01@agccert.com.

7.3. BLOCK DIAGRAM OF TEST SETUP

System Diagram of Connections between EUT and Simulators

Radiated Disturbance below 1 GHz

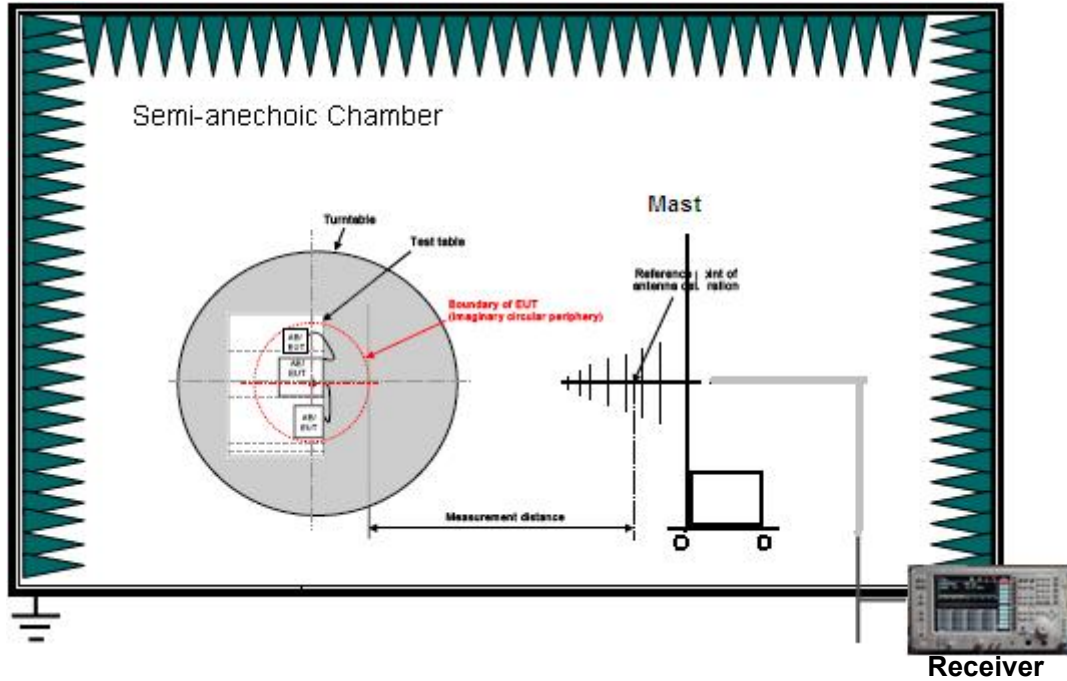

For the actual test configuration, please refer to the related item – Photographs of the Test Configuration.

Any report having not been signed by authorized approver, or having been altered without authorization, or having not been stamped by the “Dedicated Testing/Inspection Stamp” is deemed to be invalid. Copying or excerpting portion of, or altering the content of the report is not permitted without the written authorization of AGC. The test results presented in the report apply only to the tested sample. Any objections to report issued by AGC should be submitted to AGC within 15days after the issuance of the test report. Further enquiry of validity or verification of the test report should be addressed to AGC by agc01@agccert.com.

7.4 TEST RESULT

The test modes were carried out for all modes.

The worst test mode of the EUT was Mode 1, and its test data was showed as the follow:

RADIATED EMISSION BELOW 1GHZ–HORIZONTAL

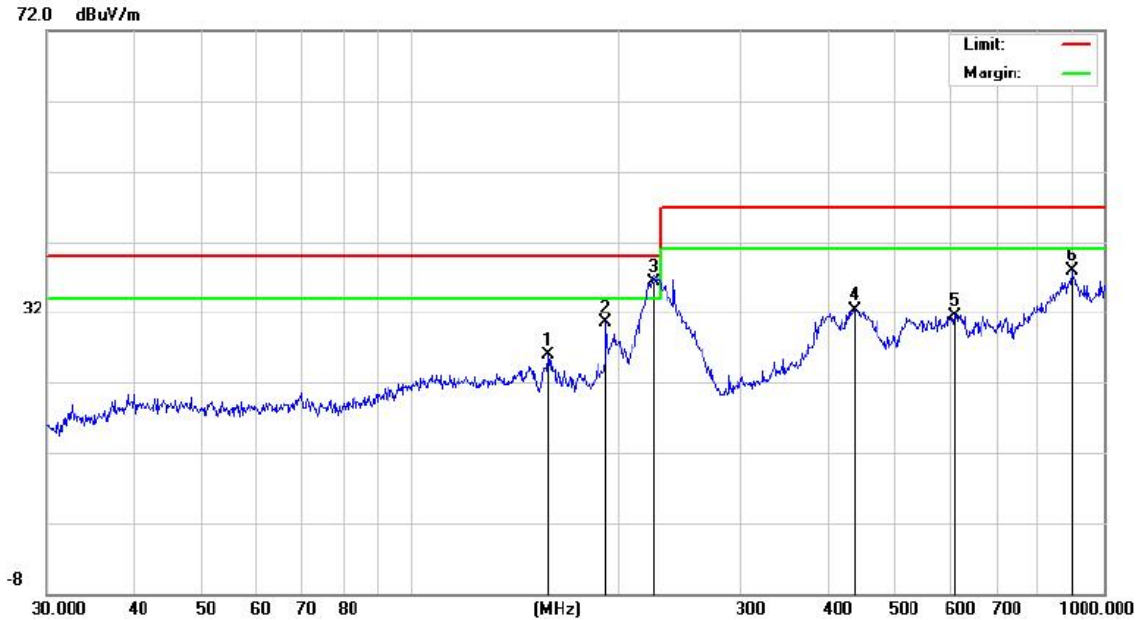

No.	Mk.	Freq. MHz	Reading Level dBuV	Correct Factor dB	Measure- ment dBuV/m	Limit dB/m	Over dB	Detector
1		158.1123	13.34	12.48	25.82	40.00	-14.18	peak
2		191.7450	16.95	13.55	30.50	40.00	-9.50	peak
3	*	224.5193	21.75	14.63	36.38	40.00	-3.62	QP
4		438.6554	7.57	24.81	32.38	47.00	-14.62	peak
5		609.9217	6.41	25.15	31.56	47.00	-15.44	peak
6		900.1474	6.05	31.78	37.83	47.00	-9.17	peak

RESULT: PASS

Any report having not been signed by authorized approver, or having been altered without authorization, or having not been stamped by the "Dedicated Testing/Inspection Stamp" is deemed to be invalid. Copying or excerpting portion of, or altering the content of the report is not permitted without the written authorization of AGC. The test results presented in the report apply only to the tested sample. Any objections to report issued by AGC should be submitted to AGC within 15days after the issuance of the test report. Further enquiry of validity or verification of the test report should be addressed to AGC by agc01@agccert.com.

RADIATED EMISSION BELOW 1GHZ-VERTICAL

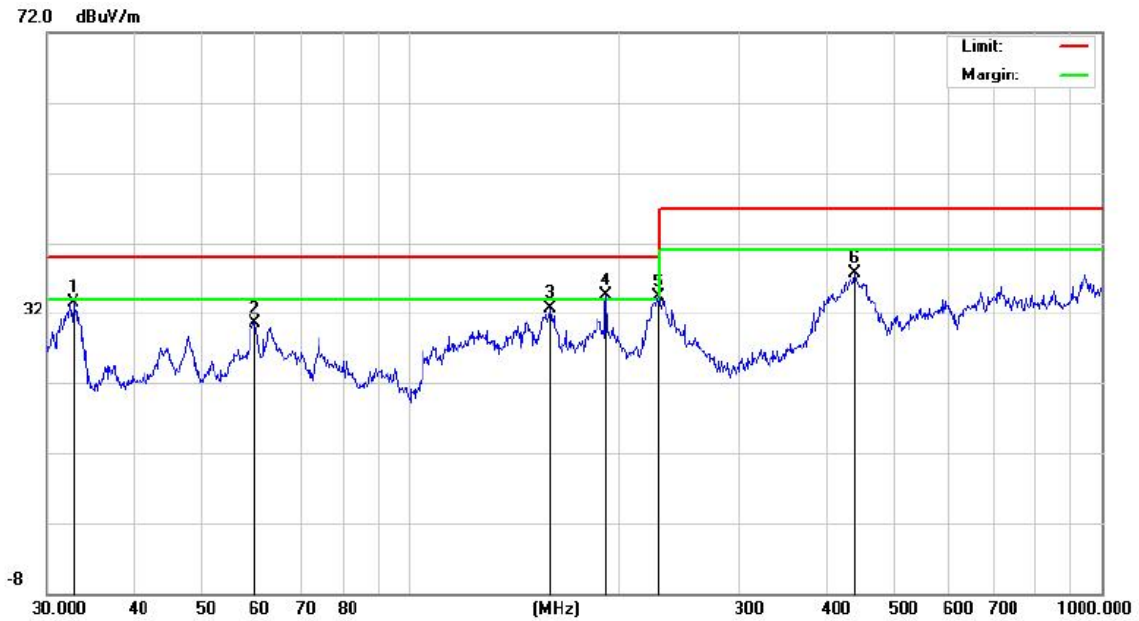

No.	Mk.	Freq. MHz	Reading Level dBuV	Correct Factor dB	Measure- ment dBuV/m	Limit dB/m	Over dB	Detector
1		32.6340	18.97	14.47	33.44	40.00	-6.56	peak
2		59.6493	13.34	17.10	30.44	40.00	-9.56	peak
3		159.7844	14.47	18.20	32.67	40.00	-7.33	peak
4	*	192.4186	16.34	18.13	34.47	40.00	-5.53	peak
5	!	228.4904	17.91	16.33	34.24	40.00	-5.76	peak
6		440.1963	11.64	26.09	37.73	47.00	-9.27	peak

RESULT: PASS

Any report having not been signed by authorized approver, or having been altered without authorization, or having not been stamped by the "Dedicated Testing/Inspection Stamp" is deemed to be invalid. Copying or excerpting portion of, or altering the content of the report is not permitted without the written authorization of AGC. The test results presented in the report apply only to the tested sample. Any objections to report issued by AGC should be submitted to AGC within 15days after the issuance of the test report. Further enquiry of validity or verification of the test report should be addressed to AGC by agc01@agccert.com.

8. MAINS TERMINAL DISTURBANCE VOLTAGE MEASUREMENT

8.1. LIMITS OF MAINS TERMINAL DISTURBANCE VOLTAGE

Frequency range (MHz)	Limits (dBuV) Class B ITE	
	Quasi-peak	Average
0.15-0.50	66 to 56	56 to 46
0.50-5	56	46
5-30	60	50

Note: 1. The lower limit shall apply at the transition frequencies.
2. The limit decreases linearly with the logarithm of the frequency in the range 0.15MHz to 0.50MHz.

8.2. TEST PROCEDURE

- (1) The EUT was placed 0.4 meters from the conducting wall of shielded room with EUT being connected to the power mains through a line impedance stabilization network (LISN). The LISN provide 50Ω/50μH of coupling impedance for the measuring instrument.
- (2) Both lines of the power mains connected to the EUT were checked for maximum conducted interference.
- (3) The frequency range from 150 kHz to 30 MHz was searched. Emission levels over 20dB under the prescribed limits are not reported.

8.3. TEST SETUP

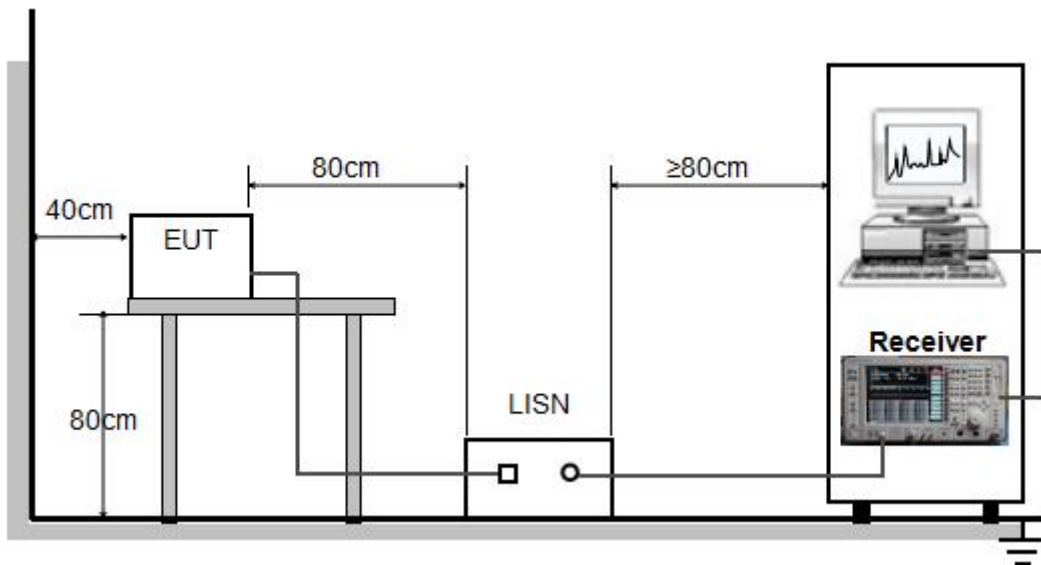

For the actual test configuration, please refer to the related item - Photographs of the Test Configuration.

Any report having not been signed by authorized approver, or having been altered without authorization, or having not been stamped by the "Dedicated Testing/Inspection Stamp" is deemed to be invalid. Copying or excerpting portion of, or altering the content of the report is not permitted without the written authorization of AGC. The test results presented in the report apply only to the tested sample. Any objections to report issued by AGC should be submitted to AGC within 15 days after the issuance of the test report. Further enquiry of validity or verification of the test report should be addressed to AGC by agc01@agccert.com.

8.4. TEST RESULT

The test modes were carried out for all modes.

The worst test mode of the EUT was Mode 2, and its test data was showed as the follow:

LINE CONCUTED EMISSION TEST-L

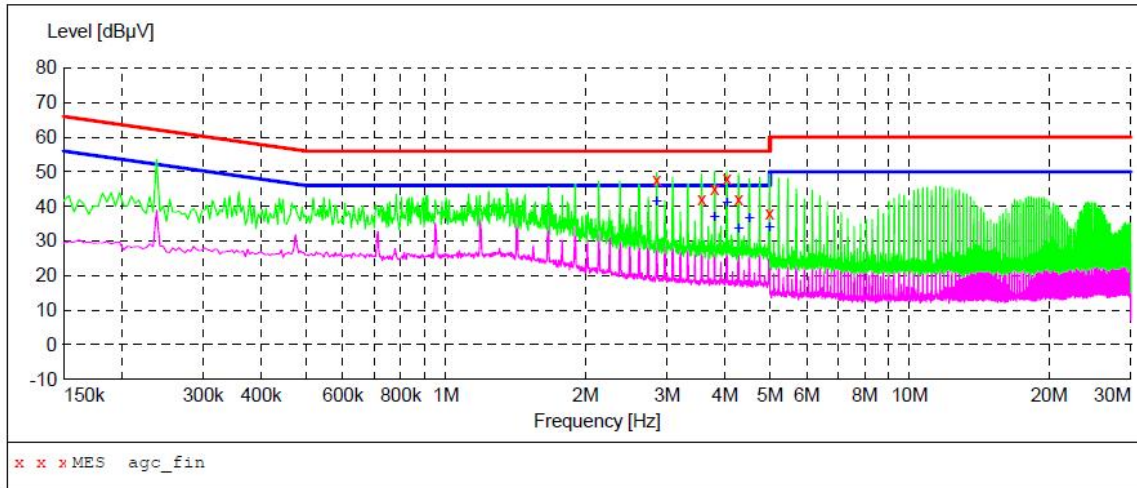

MEASUREMENT RESULT: "agc_fin"

2023/10/30 11:38

Frequency MHz	Level dBµV	Transd dB	Limit dBµV	Margin dB	Detector	Line
2.850000	47.50	6.3	56	8.5	QP	L1
3.566000	42.20	6.3	56	13.8	QP	L1
3.802000	45.10	6.3	56	10.9	QP	L1
4.038000	47.90	6.3	56	8.1	QP	L1
4.278000	41.90	6.3	56	14.1	QP	L1
4.990000	37.80	6.3	56	18.2	QP	L1

MEASUREMENT RESULT: "agc_fin2"

2023/10/30 11:38

Frequency MHz	Level dBµV	Transd dB	Limit dBµV	Margin dB	Detector	Line
2.850000	41.20	6.3	46	4.8	AV	L1
3.802000	37.00	6.3	46	9.0	AV	L1
4.038000	41.10	6.3	46	4.9	AV	L1
4.278000	33.50	6.3	46	12.5	AV	L1
4.514000	36.50	6.3	46	9.5	AV	L1
4.990000	33.90	6.3	46	12.1	AV	L1

RESULT: PASS

Any report having not been signed by authorized approver, or having been altered without authorization, or having not been stamped by the "Dedicated Testing/Inspection Stamp" is deemed to be invalid. Copying or excerpting portion of, or altering the content of the report is not permitted without the written authorization of AGC. The test results presented in the report apply only to the tested sample. Any objections to report issued by AGC should be submitted to AGC within 15days after the issuance of the test report. Further enquiry of validity or verification of the test report should be addressed to AGC by agc01@agccert.com.

LINE CONDUCTED EMISSION TEST-N

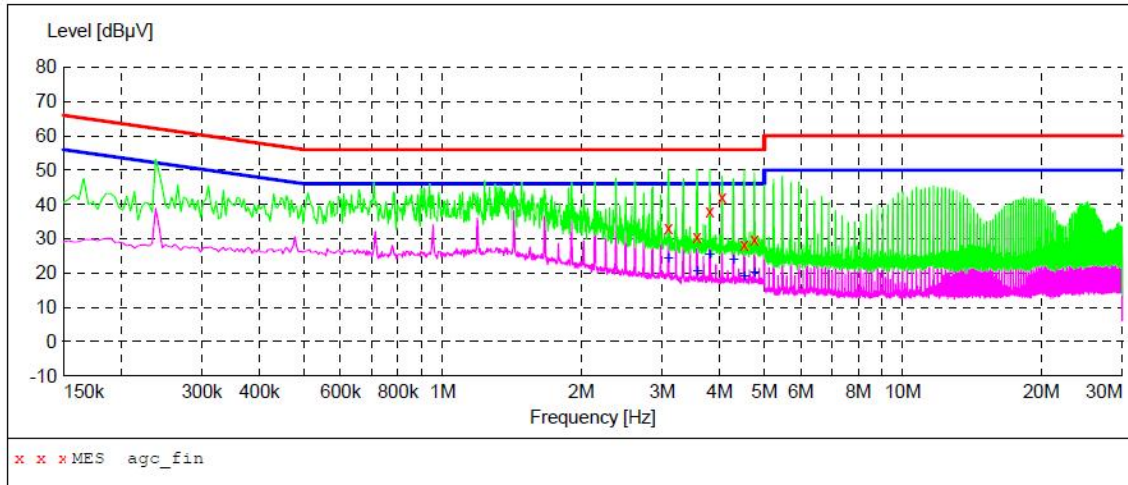

MEASUREMENT RESULT: "agc_fin"

2023/10/30 11:34

Frequency MHz	Level dBµV	Transd dB	Limit dBµV	Margin dB	Detector	Line
3.098000	33.30	6.3	56	22.7	QP	N
3.574000	30.60	6.3	56	25.4	QP	N
3.810000	37.90	6.3	56	18.1	QP	N
4.046000	42.00	6.3	56	14.0	QP	N
4.526000	28.10	6.3	56	27.9	QP	N
4.762000	29.60	6.3	56	26.4	QP	N

MEASUREMENT RESULT: "agc_fin2"

2023/10/30 11:34

Frequency MHz	Level dBµV	Transd dB	Limit dBµV	Margin dB	Detector	Line
3.098000	24.10	6.3	46	21.9	AV	N
3.574000	20.60	6.3	46	25.4	AV	N
3.810000	25.40	6.3	46	20.6	AV	N
4.286000	23.90	6.3	46	22.1	AV	N
4.526000	18.80	6.3	46	27.2	AV	N
4.762000	19.90	6.3	46	26.1	AV	N

RESULT: PASS

Any report having not been signed by authorized approver, or having been altered without authorization, or having not been stamped by the "Dedicated Testing/Inspection Stamp" is deemed to be invalid. Copying or excerpting portion of, or altering the content of the report is not permitted without the written authorization of AGC. The test results presented in the report apply only to the tested sample. Any objections to report issued by AGC should be submitted to AGC within 15days after the issuance of the test report. Further enquiry of validity or verification of the test report should be addressed to AGC by agc01@agccert.com.

9. HARMONIC CURRENT MEASUREMENT

9.1. LIMITS OF HARMONIC CURRENT

Limits for Class A Equipment	
Harmonics Order n	Max. permissible harmonic current (A)
Odd harmonics	
3	2.30
5	1.14
7	0.77
9	0.40
11	0.33
13	0.21
15≤n≤39	0.15×15/n
Even harmonics	
2	1.08
4	0.43
6	0.30
8≤n≤40	0.23×8/n

Note: 1. According to section 5 of EN IEC 61000-3-2:2019/A1:2021, the EUT is Class A equipment.

2. The above limits are for all applications having an active input power >75W. No limits apply for equipment with an active input power up to and including 75W.

9.2. TEST PROCEDURE

- The EUT was placed on the top of a wooden table 0.8 meters above the ground and operated to produce the maximum harmonic components under normal operating conditions for each successive harmonic component in turn.
- The correspondent test program of test instrument to measure the current harmonics emanated from EUT is chosen. The measure time shall be not less than the necessary for the EUT to be exercised.

Any report having not been signed by authorized approver, or having been altered without authorization, or having not been stamped by the "Dedicated Testing/Inspection Stamp" is deemed to be invalid. Copying or excerpting portion of, or altering the content of the report is not permitted without the written authorization of AGC. The test results presented in the report apply only to the tested sample. Any objections to report issued by AGC should be submitted to AGC within 15 days after the issuance of the test report. Further enquiry of validity or verification of the test report should be addressed to AGC by agc01@agccert.com.

9.3. TEST SETUP

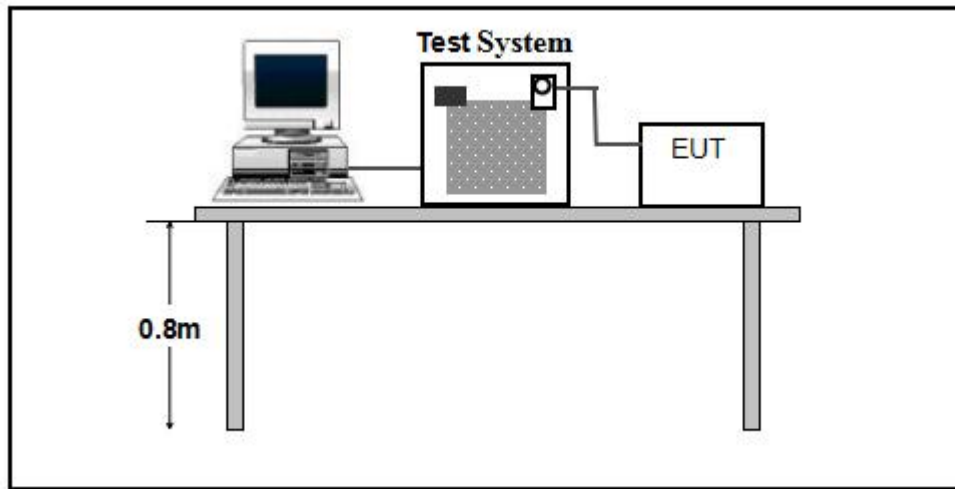

For the actual test configuration, please refer to Appendix I : Photographs of the Test Configuration.

9.4. TEST RESULT

Note: Equipment with a rated power less than or equal to 75W is deemed to fulfilled all relevant requirements of this standard without testing.

Any report having not been signed by authorized approver, or having been altered without authorization, or having not been stamped by the "Dedicated Testing/Inspection Stamp" is deemed to be invalid. Copying or excerpting portion of, or altering the content of the report is not permitted without the written authorization of AGC. The test results presented in the report apply only to the tested sample. Any objections to report issued by AGC should be submitted to AGC within 15days after the issuance of the test report. Further enquiry of validity or verification of the test report should be addressed to AGC by agc01@agccert.com.

10. VOLTAGE FLUCTUATIONS AND FLICK MEASUREMENT

10.1. LIMITS OF VOLTAGE FLUCTUATIONS AND FLICK

Test Item	Limit	Note
P_{st}	1.0	P_{st} means Short-term flicker indicator
P_{lt}	0.65	P_{lt} means long-term flicker indicator
T_{dt}	0.5	T_{dt} means maximum time that d_t exceeds 3.3%
$d_{max}(\%)$	4%	d_{max} means maximum relative voltage change.
$d_c(\%)$	3.3%	d_c means relative steady-state voltage change.

10.2. TEST PROCEDURE

1. The EUT was placed on the top of a wooden table 0.8 meters above the ground and operated to produce the most unfavorable sequence of voltage changes under normal conditions
2. During the flick measurement, the measure time shall include that part of whole operation changes. The observation period for short-term flicker indicator is 10 minutes and the observation period for long-term flicker indicator is 2 hours.

10.3. TEST SETUP

Same as 9.3

10.4. TEST RESULT

Test Specification

Test Frequency	50Hz	Test Voltage	230V AC
Waveform	Sine	Test Time	10 minutes(P_{st}); 2 hours (P_{lt})

Test Result

The worst test mode of the EUT was **Mode 1**, and its test data was showed as the follow:

Test Parameter	Measurement Value	Limit	Remarks
Time(mS) > dt:	0.0	500.0	Pass
Highest dc (%):	0.00	3.30	Pass
Highest dmax (%):	0.00	4.00	Pass
Highest Pst (10 min. period):	0.248	1.000	Pass
Highest Plt (2 hr. period):	0.108	0.650	Pass

Note: operating mode include all modes of EMS in page 9.

11. IMMUNITY TEST

11.1. DESCRIPTION OF PERFORMANCE CRITERIA

The performance criteria are used to take a decision on whether a radio equipment passes or fails immunity tests.

For the purpose of the present document two categories of performance criteria apply:

- Performance criteria for continuous phenomena.
- Performance criteria for transient phenomena.

11.2. GENERAL PERFORMANCE CRITERIA

1. Performance criteria for continuous phenomena

During the test, the equipment shall:

- continue to operate as intended;
- not unintentionally transmit;
- not unintentionally change its operating state;
- not unintentionally change critical stored data.

2. Performance criteria for transient phenomena

For all ports and transient phenomena with the exception described below, the following applies:

- The application of the transient phenomena shall not result in a change of the mode of operation (e.g. unintended transmission) or the loss of critical stored data.
- After application of the transient phenomena, the equipment shall operate as intended.

For surges applied to symmetrically operated wired network ports intended to be connected directly to outdoor lines the following criteria applies:

- For products with only one symmetrical port intended for connection to outdoor lines, loss of function is allowed, provided the function is self-recoverable, or can be otherwise restored. Information stored in non-volatile memory, or protected by a battery backup, shall not be lost.
- For products with more than one symmetrical port intended for connection to outdoor lines, loss of function on the port under test is allowed, provided the function is self-recoverable. Information stored in non-volatile memory, or protected by a battery backup, shall not be lost.

For a 0 % residual voltage dip tests the following performance criteria apply:

- The performance criteria for transient phenomena shall apply.

For a 70 % residual voltage dip and voltage interruption tests, the following performance criteria apply:

- in the case where the equipment is fitted with or connected to a battery back-up, the performance criteria for transient phenomena shall apply;
- in the case where the equipment is powered solely from the AC mains supply (without the use of a parallel battery back-up) volatile user data may have been lost and if applicable the communication link need not to be maintained and lost functions should be recoverable by user or operator;
- no unintentional responses shall occur at the end of the test, when the voltage is restored to nominal;
- in the event of loss of function(s) or in the event of loss of user stored data, this fact shall be recorded.

Any report having not been signed by authorized approver, or having been altered without authorization, or having not been stamped by the "Dedicated Testing/Inspection Stamp" is deemed to be invalid. Copying or excerpting portion of, or altering the content of the report is not permitted without the written authorization of AGC. The test results presented in the report apply only to the tested sample. Any objections to report issued by AGC should be submitted to AGC within 15days after the issuance of the test report. Further enquiry of validity or verification of the test report should be addressed to AGC by agc01@agccert.com.

Attestation of Global Compliance(Shenzhen)Co., Ltd

Attestation of Global Compliance(Shenzhen)Std & Tech Co., Ltd

Tel: +86-755 2523 4088 E-mail: agc@agccert.com Web: <http://www.agccert.com/>

3. Performance Table

EN 301 489-3 Performance criteria		
Criteria	During Test	After Test
A	Operate as intended No loss of function No unintentional responses	Operate as intended No loss of function No degradation of performance No loss of stored data or user programmable functions
B	May show loss of function No unintentional responses	Operate as intended Lost function(s) shall be self-recoverable No degradation of performance No loss of stored data or user programmable functions
<ul style="list-style-type: none"> • performance criterion A applies for immunity tests with phenomena of a continuous nature; • performance criterion B applies for immunity tests with phenomena of a transient nature. 		
<p>Where "operate as intended" or "no loss of function" is specified, the EUT shall demonstrate correct functioning as described in EN 301 489-3 clause 5.</p> <p>Where the EUT has more than one mode of operation, an unplanned transition from one mode to another is considered as an unintentional response. The EUT shall be tested in sufficient modes to confirm there are no such unintentional responses.</p>		

Any report having not been signed by authorized approver, or having been altered without authorization, or having not been stamped by the "Dedicated Testing/Inspection Stamp" is deemed to be invalid. Copying or excerpting portion of, or altering the content of the report is not permitted without the written authorization of AGC. The test results presented in the report apply only to the tested sample. Any objections to report issued by AGC should be submitted to AGC within 15days after the issuance of the test report. Further enquiry of validity or verification of the test report should be addressed to AGC by agc01@agccert.com.

12. ELECTROSTATIC DISCHARGE IMMUNITY TEST

12.1. TEST SPECIFICATION

Basic Standard	EN 61000-4-2
Discharge Impedance	330Ω/150 pF
Discharge Voltage	Air Discharge:±8kV, Contact Discharge:±4kV
Polarity	Positive/Negative
Number of Discharge	Minimum 25 times at each test point
Discharge Mode	Single discharge
Discharge Period	1-second minimum

12.2. TEST PROCEDURE

The test procedure was in accordance with EN 61000-4-2:

- a. Electrostatic discharges were applied only to those points and surfaces of the EUT that are accessible to users during normal operation.
- b. The test was performed with at least ten single discharges on the pre-selected points in the most sensitive polarity.
- c. The time interval between two successive single discharges was at least 1 second.
- d. The ESD generator was held perpendicularly to the surface to which the discharge was applied and the return cable was at least 0.2 meters from the EUT.
- e. Contact discharges were applied to the non-insulating coating, with the pointed tip of the generator penetrating the coating and contacting the conducting substrate.
- f. Air discharges were applied with the round discharge tip of the discharge electrode approaching the EUT as fast as possible (without causing mechanical damage) to touch the EUT. After each discharge, the ESD generator was removed from the EUT and re-triggered for a new single discharge. The test was repeated until all discharges were completed.
- g. At least ten single discharges (in the most sensitive polarity) were applied to the Horizontal Coupling Plane at points on each side of the EUT. The ESD generator was positioned vertically at a distance of 0.1 meters from the EUT with the discharge electrode touching the HCP.
- h. At least ten single discharges (in the most sensitive polarity) were applied to the center of one vertical edge of the Vertical Coupling Plane in sufficiently different positions that the four faces of the EUT were completely illuminated. The VCP (dimensions 0.5m×0.5m) was placed vertically to and 0.1 meters from the EUT.

Any report having not been signed by authorized approver, or having been altered without authorization, or having not been stamped by the "Dedicated Testing/Inspection Stamp" is deemed to be invalid. Copying or excerpting portion of, or altering the content of the report is not permitted without the written authorization of AGC. The test results presented in the report apply only to the tested sample. Any objections to report issued by AGC should be submitted to AGC within 15days after the issuance of the test report. Further enquiry of validity or verification of the test report should be addressed to AGC by agc01@agccert.com.

12.3. TEST SETUP

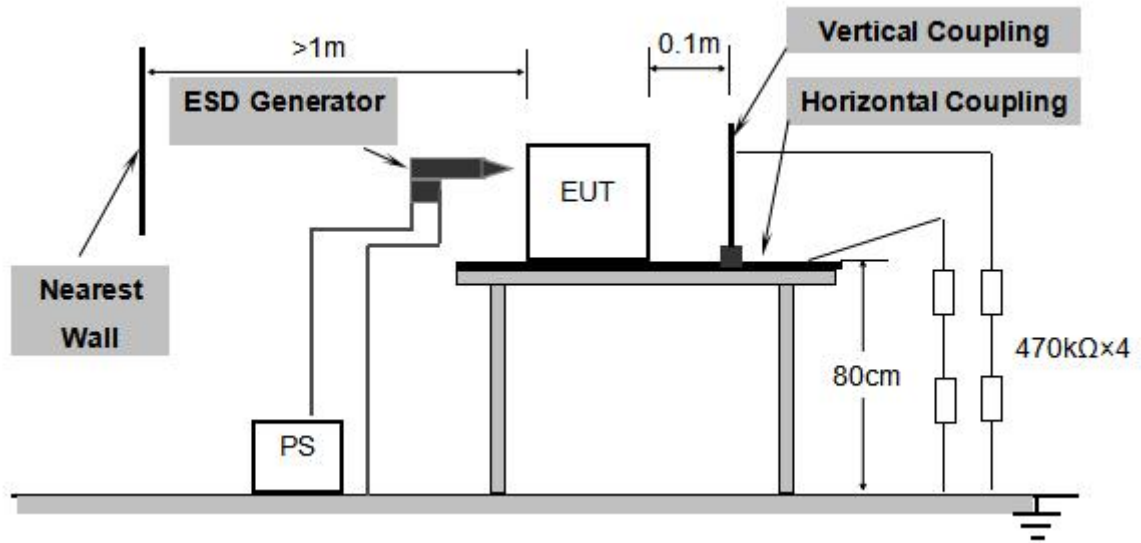

For the actual test configuration, please refer to Appendix I: Photographs of the Test Configuration.

Any report having not been signed by authorized approver, or having been altered without authorization, or having not been stamped by the "Dedicated Testing/Inspection Stamp" is deemed to be invalid. Copying or excerpting portion of, or altering the content of the report is not permitted without the written authorization of AGC. The test results presented in the report apply only to the tested sample. Any objections to report issued by AGC should be submitted to AGC within 15days after the issuance of the test report. Further enquiry of validity or verification of the test report should be addressed to AGC by agc01@agccert.com.

ESD location:

Blue line: Air discharge



Any report having not been signed by authorized approver, or having been altered without authorization, or having not been stamped by the "Dedicated Testing/Inspection Stamp" is deemed to be invalid. Copying or excerpting portion of, or altering the content of the report is not permitted without the written authorization of AGC. The test results presented in the report apply only to the tested sample. Any objections to report issued by AGC should be submitted to AGC within 15days after the issuance of the test report. Further enquiry of validity or verification of the test report should be addressed to AGC by agc01@agccert.com.

Attestation of Global Compliance(Shenzhen)Co., Ltd

Attestation of Global Compliance(Shenzhen)Std & Tech Co., Ltd

Tel: +86-755 2523 4088 E-mail: agc@agccert.com Web: <http://www.agccert.com/>

12.4. TEST RESULT

Times of Discharge	Voltage	Coupling	Test Mode	Performance criteria
Mini 25 / Point	±2kV; ±4kV	Contact discharge	N/A	N/A
Mini 25 / Point	±2kV; ±4kV; ±8kV	Air Discharge	Mode 1/2/3	A
Mini 25 / Point	±4kV	Indirect Discharge HCP	Mode 1/2/3	A
Mini 25 / Point	±4kV	Indirect Discharge VCP	Mode 1/2/3	A

A: No degradation in the performance of the EUT was observed.

12.5. PERFORMANCE

<input checked="" type="checkbox"/> Criteria A:	The apparatus continues to operate as intended. No degradation of performance or loss of function is allowed below a performance level specified by the manufacturer, when the apparatus is used as intended. In some cases the performance level may be replaced by a permissible loss of performance.
<input type="checkbox"/> Criteria B:	The apparatus continues to operate as intended after the test. No degradation of performance or loss of function is allowed below a performance level specified by the manufacturer, when the apparatus is used as intended. In some cases the performance level may be replaced by a permissible loss of performance. During the test, degradation of performance is however allowed.
<input type="checkbox"/> Criteria C:	Temporary loss of function is allowed, provided the functions self recoverable or can be restored by the operation of controls.

Compliance **Not Compliance**

Any report having not been signed by authorized approver, or having been altered without authorization, or having not been stamped by the "Dedicated Testing/Inspection Stamp" is deemed to be invalid. Copying or excerpting portion of, or altering the content of the report is not permitted without the written authorization of AGC. The test results presented in the report apply only to the tested sample. Any objections to report issued by AGC should be submitted to AGC within 15days after the issuance of the test report. Further enquiry of validity or verification of the test report should be addressed to AGC by agc01@agccert.com.

13. RADIATED, RADIO FREQUENCY ELECTROMAGNETIC FIELD IMMUNITY TEST

13.1. TEST SPECIFICATION

Basic Standard	EN 61000-4-3
Frequency Range	80MHz–6000MHz
Field Strength	3V/m
Modulation	1 kHz sine wave, 80%, AM modulation
Frequency Step	1% of fundamental
Polarity of Antenna	Horizontal and Vertical
Test Distance	3m
Antenna Height	1.55m
Dwell Time	3 seconds

13.2. TEST PROCEDURE

The test procedure was in accordance with EN 61000-4-3.

- a. The testing was performed in a fully anechoic chamber. The transmit antenna was located at a distance of 3 meters from the EUT.
- b. The test signal was 80% amplitude modulated with a 1 kHz sine wave.
- c. The frequency range was swept from 80 MHz to 6000MHz with the exception of the exclusion band for transmitters, receivers and duplex transceivers. The rate of sweep did not exceed 1.5×10^{-3} decade/s. Where the frequency range is swept incrementally, the step size was 1% of fundamental.
- d. The dwell time at each frequency shall be not less than the time necessary for the EUT to be able to respond.
- e. The field strength level was 3V/m.
- f. The test was performed with the EUT exposed to both vertically and horizontally polarized fields on each of the four sides.

Any report having not been signed by authorized approver, or having been altered without authorization, or having not been stamped by the “Dedicated Testing/Inspection Stamp” is deemed to be invalid. Copying or excerpting portion of, or altering the content of the report is not permitted without the written authorization of AGC. The test results presented in the report apply only to the tested sample. Any objections to report issued by AGC should be submitted to AGC within 15days after the issuance of the test report. Further enquiry of validity or verification of the test report should be addressed to AGC by agc01@agccert.com.

13.3. TEST SETUP

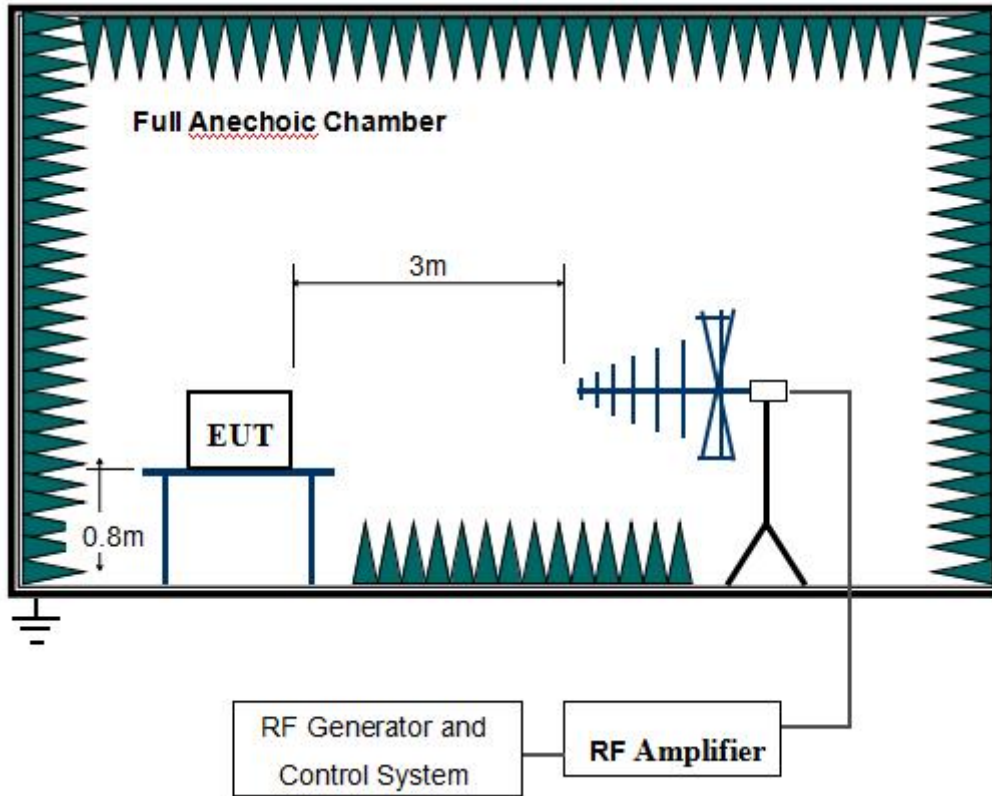

For the actual test configuration, please refer to Appendix I: Photographs of the Test Configuration.

Any report having not been signed by authorized approver, or having been altered without authorization, or having not been stamped by the “Dedicated Testing/Inspection Stamp” is deemed to be invalid. Copying or excerpting portion of, or altering the content of the report is not permitted without the written authorization of AGC. The test results presented in the report apply only to the tested sample. Any objections to report issued by AGC should be submitted to AGC within 15days after the issuance of the test report. Further enquiry of validity or verification of the test report should be addressed to AGC by agc01@agccert.com.

13.4. TEST RESULT

Freq. Range (MHz)	Field	Modulation	Polarity	Position	Test Mode	Performance criteria
80-6000	3V/m	Yes	H	Front	Mode 1/2/3	A
80-6000	3V/m	Yes	H	Back	Mode 1/2/3	A
80-6000	3V/m	Yes	H	Left	Mode 1/2/3	A
80-6000	3V/m	Yes	H	Right	Mode 1/2/3	A
80-6000	3V/m	Yes	V	Front	Mode 1/2/3	A
80-6000	3V/m	Yes	V	Back	Mode 1/2/3	A
80-6000	3V/m	Yes	V	Left	Mode 1/2/3	A
80-6000	3V/m	Yes	V	Right	Mode 1/2/3	A

A: No degradation in the performance of the EUT was observed.

13.5. PERFORMANCE

<input checked="" type="checkbox"/> Criteria A:	The apparatus continues to operate as intended. No degradation of performance or loss of function is allowed below a performance level specified by the manufacturer, when the apparatus is used as intended. In some cases the performance level may be replaced by a permissible loss of performance.
<input type="checkbox"/> Criteria B:	The apparatus continues to operate as intended after the test. No degradation of performance or loss of function is allowed below a performance level specified by the manufacturer, when the apparatus is used as intended. In some cases the performance level may be replaced by a permissible loss of performance. During the test, degradation of performance is however allowed.
<input type="checkbox"/> Criteria C:	Temporary loss of function is allowed, provided the functions self recoverable or can be restored by the operation of controls.
<input checked="" type="checkbox"/> Compliance <input type="checkbox"/> Not Compliance	

Any report having not been signed by authorized approver, or having been altered without authorization, or having not been stamped by the "Dedicated Testing/Inspection Stamp" is deemed to be invalid. Copying or excerpting portion of, or altering the content of the report is not permitted without the written authorization of AGC. The test results presented in the report apply only to the tested sample. Any objections to report issued by AGC should be submitted to AGC within 15days after the issuance of the test report. Further enquiry of validity or verification of the test report should be addressed to AGC by agc01@agccert.com.

14. ELECTRICAL FAST TRANSIENT/BURST IMMUNITY TEST

14.1. TEST SPECIFICATION

Basic Standard	EN 61000-4-4
Test Voltage	a.c. power port-1kV
Polarity	Positive/Negative
Impulse Frequency	5kHz
Impulse wave shape	5/50ns
Burst Duration	15ms
Burst Period	300ms
Test Duration	Not less than 1min.

14.2. TEST PROCEDURE

1. The EUT was tested with 1000 volt discharges to the AC power input leads.
2. Both positive and negative polarity discharges were applied.
3. The length of the “hot wire” from the coaxial output of the EFT generator to the terminals on the EUT should not exceed 1 meter.
4. The duration time of each test sequential was 1 minute.
5. The transient/burst waveform was in accordance with IEC 61000-4-4, 5/50ns.

14.3. TEST SETUP

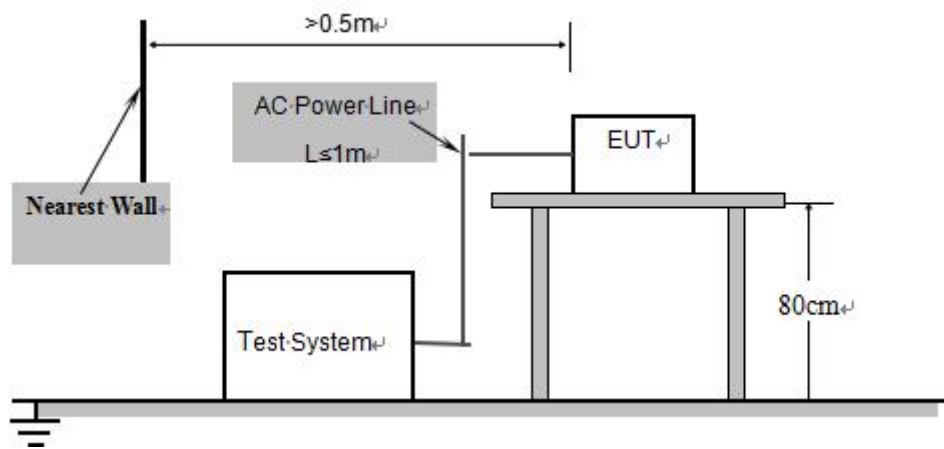

For the actual test configuration, please refer to Appendix I : Photographs of the Test Configuration.

Any report having not been signed by authorized approver, or having been altered without authorization, or having not been stamped by the “Dedicated Testing/Inspection Stamp” is deemed to be invalid. Copying or excerpting portion of, or altering the content of the report is not permitted without the written authorization of AGC. The test results presented in the report apply only to the tested sample. Any objections to report issued by AGC should be submitted to AGC within 15days after the issuance of the test report. Further enquiry of validity or verification of the test report should be addressed to AGC by agc01@agccert.com.

14.4. TEST RESULT

Test Point	Polarity	Test Level (kV)	Test Mode	Performance criteria
a.c. port, L	+/-	1	Mode 1/2/3	A
a.c. port, N	+/-	1	Mode 1/2/3	A
a.c. port, L-N	+/-	1	Mode 1/2/3	A

A: No degradation in the performance of the EUT was observed.

Note: operating mode include all modes of EMS in page 9.

14.5. PERFORMANCE

<input checked="" type="checkbox"/> Criteria A:	The apparatus continues to operate as intended. No degradation of performance or loss of function is allowed below a performance level specified by the manufacturer, when the apparatus is used as intended. In some cases the performance level may be replaced by a permissible loss of performance.
<input type="checkbox"/> Criteria B:	The apparatus continues to operate as intended after the test. No degradation of performance or loss of function is allowed below a performance level specified by the manufacturer, when the apparatus is used as intended. In some cases the performance level may be replaced by a permissible loss of performance. During the test, degradation of performance is however allowed.
<input type="checkbox"/> Criteria C:	Temporary loss of function is allowed, provided the functions self-recoverable or can be restored by the operation of controls.

Compliance **Not Compliance**

Any report having not been signed by authorized approver, or having been altered without authorization, or having not been stamped by the "Dedicated Testing/Inspection Stamp" is deemed to be invalid. Copying or excerpting portion of, or altering the content of the report is not permitted without the written authorization of AGC. The test results presented in the report apply only to the tested sample. Any objections to report issued by AGC should be submitted to AGC within 15days after the issuance of the test report. Further enquiry of validity or verification of the test report should be addressed to AGC by agc01@agccert.com.

15. SURGE IMMUNITY TEST

15.1. TEST SPECIFICATION

Basic Standard	EN 61000-4-5
Waveform	Voltage 1.2/50µs; Current 8/20µs
Test Voltage	a.c. power port, line to line 1.0kV
Polarity	Positive/Negative
Phase Angle	0°, 90°, 180°, 270°
Repetition Rate	60sec
Times	5 time/each condition.

15.2. TEST PROCEDURE

- The EUT and the auxiliary equipment were placed on a table of 0.8m heights above a metal ground reference plane. The size of ground plane is greater than 1m×1m and project beyond the EUT by at least 0.1m on all sides. The ground plane is connected to the protective earth. The length of power cord between the coupling device and the EUT was less than 2 meters (provided by the manufacturer).
- The EUT was connected to the power mains through a coupling device that directly couples the surge interference signal. The surge noise was applied synchronized to the voltage phase at the zero crossing and the peak value of the AC voltage wave (positive and negative).
- The surges were applied line to line and line(s) to earth. All lower levels including the selected test level were tested. The polarity of each surge level included positive and negative test pulses.

15.3. TEST SETUP

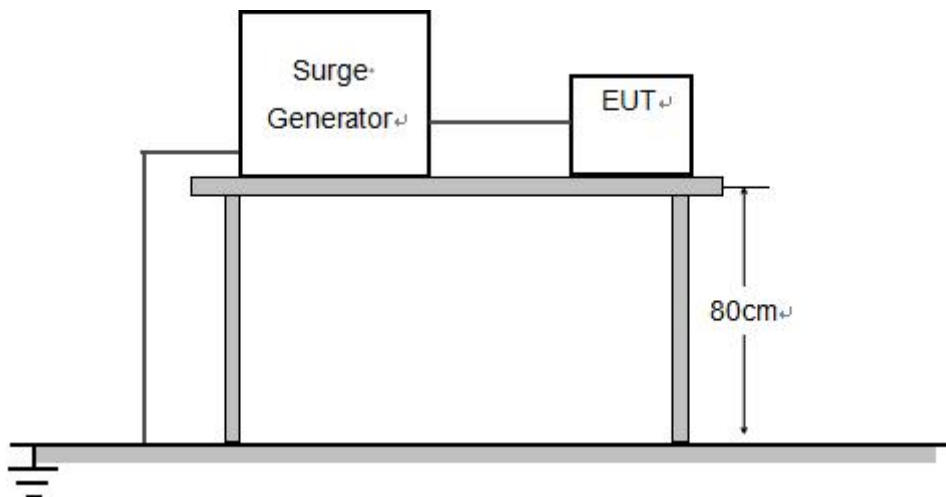

For the actual test configuration, please refer to Appendix I : Photographs of the Test Configuration.

Any report having not been signed by authorized approver, or having been altered without authorization, or having not been stamped by the "Dedicated Testing/Inspection Stamp" is deemed to be invalid. Copying or excerpting portion of, or altering the content of the report is not permitted without the written authorization of AGC. The test results presented in the report apply only to the tested sample. Any objections to report issued by AGC should be submitted to AGC within 15days after the issuance of the test report. Further enquiry of validity or verification of the test report should be addressed to AGC by agc01@agccert.com.

15.4. TEST RESULT

Coupling Line	Polarity	Voltage (kV)	Test Mode	Performance criteria
a.c. power, L-N	+/-	1.0	Mode 1/2/3	A

A: No degradation in the performance of the EUT was observed.

Note: operating mode include all modes of EMS in page 9.

15.5. PERFORMANCE

<input checked="" type="checkbox"/> Criteria A:	The apparatus continues to operate as intended. No degradation of performance or loss of function is allowed below a performance level specified by the manufacturer, when the apparatus is used as intended. In some cases the performance level may be replaced by a permissible loss of performance.
<input type="checkbox"/> Criteria B:	The apparatus continues to operate as intended after the test. No degradation of performance or loss of function is allowed below a performance level specified by the manufacturer, when the apparatus is used as intended. In some cases the performance level may be replaced by a permissible loss of performance. During the test, degradation of performance is however allowed.
<input type="checkbox"/> Criteria C:	Temporary loss of function is allowed, provided the functions self recoverable or can be restored by the operation of controls.

Compliance **Not Compliance**

16. IMMUNITY TO CONDUCTED DISTURBANCES INDUCED BY RF FIELDS

16.1. TEST SPECIFICATION

Basic Standard	EN 61000-4-6
Frequency Range	0.15MHz–80MHz
Field Strength	3Vrms
Modulation	1 kHz Sine Wave, 80% AM
Frequency Step	1% of fundamental
Coupled Cable	a.c. power line
Coupling Device	CDN-M2

16.2. TEST PROCEDURE

1. The EUT shall be tested within its intended operating and climatic conditions.
2. The test shall be performed with the test generator connected to each of the coupling and decoupling devices in turn, while the other non-excited RF input ports of the coupling devices are terminated by a 50-ohm load resistor.
3. The test signal was 80% amplitude modulated with a 1 kHz sine wave
4. The frequency range is swept from 150 kHz to 80 MHz, using the signal level established during the setting process and with a disturbance signal of 80% amplitude. The sweep rate shall not exceed 1.5×10^{-3} decades/s. The step size shall not exceed 1% of the start and thereafter 1% of the preceding frequency value where the frequency is swept incrementally.
5. The dwell time at each frequency shall not be less than the time necessary for the EUT to be exercised, and able to respond. Sensitive frequencies such as clock frequencies and harmonics or frequencies of dominant interest, shall be analyzed separately.
6. Attempts should be made to fully exercise the EUT during test, and to fully interrogate all exercise modes selected for susceptibility.

16.3. TEST SETUP

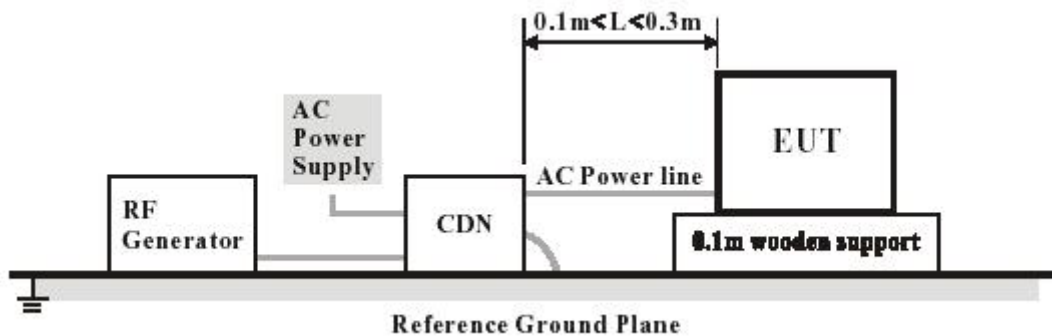

For the actual test configuration, please refer to Appendix I : Photographs of the Test Configuration.

Any report having not been signed by authorized approver, or having been altered without authorization, or having not been stamped by the “Dedicated Testing/Inspection Stamp” is deemed to be invalid. Copying or excerpting portion of, or altering the content of the report is not permitted without the written authorization of AGC. The test results presented in the report apply only to the tested sample. Any objections to report issued by AGC should be submitted to AGC within 15days after the issuance of the test report. Further enquiry of validity or verification of the test report should be addressed to AGC by agc01@agccert.com.

16.4. TEST RESULT

Test Point	Frequency (MHz)	Level (V rms)	Test Mode	Performance criteria
a.c. port	0.15 – 80	3	Mode 1/2/3	A

A: No degradation in the performance of the EUT was observed.

Note: operating mode include all modes of EMS in page 9.

16.5. PERFORMANCE

<input checked="" type="checkbox"/> Criteria A:	The apparatus continues to operate as intended. No degradation of performance or loss of function is allowed below a performance level specified by the manufacturer, when the apparatus is used as intended. In some cases the performance level may be replaced by a permissible loss of performance.
<input type="checkbox"/> Criteria B:	The apparatus continues to operate as intended after the test. No degradation of performance or loss of function is allowed below a performance level specified by the manufacturer, when the apparatus is used as intended. In some cases the performance level may be replaced by a permissible loss of performance. During the test, degradation of performance is however allowed.
<input type="checkbox"/> Criteria C:	Temporary loss of function is allowed, provided the functions self-recoverable or can be restored by the operation of controls.

Compliance **Not Compliance**

Any report having not been signed by authorized approver, or having been altered without authorization, or having not been stamped by the “Dedicated Testing/Inspection Stamp” is deemed to be invalid. Copying or excerpting portion of, or altering the content of the report is not permitted without the written authorization of AGC. The test results presented in the report apply only to the tested sample. Any objections to report issued by AGC should be submitted to AGC within 15days after the issuance of the test report. Further enquiry of validity or verification of the test report should be addressed to AGC by agc01@agccert.com.

17. VOLTAGE DIPS AND SHORT INTERRUPTIONS IMMUNITY TEST

17.1. TEST SPECIFICATION

Basic Standard	EN 61000-4-11
Voltage Dips	100% reduction, 0.5 Cycle 100% reduction, 1.0 Cycle 30% reduction, 25 Cycles
Voltage Interruptions	100% reduction, 250 Cycles
Voltage Phase Angle	0°, 45°, 90°, 135°, 180°, 225°, 270°, 315°

17.2. TEST PROCEDURE

- The power cord was used as supplied by the manufacturer. The EUT was connected to the line output of the Voltage Dips and Interruption Generator.
- The EUT was tested for (1) 100% voltage dip of supplied voltage with duration of 0.5 cycles, (2) 100% voltage dip of supplied voltage and duration 1.0 cycle. (3) 30% voltage dip of supplied voltage and duration 25 cycles. (4) 100% voltage interruption of supplied voltage with duration of 250 Cycles was followed.
- Voltage reductions occur at 0 degree crossover point of the voltage waveform. The performance of the EUT was checked after the voltage dip or interruption.

17.3. TEST SETUP

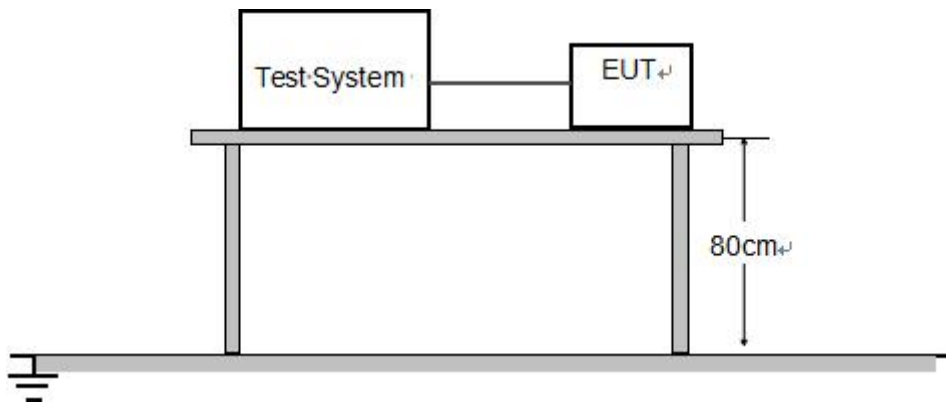

For the actual test configuration, please refer to Appendix I, Photographs of the Test Configuration.

17.4. TEST RESULT

Test Mode	Voltage Reduction	Duration (cycle)	Times	Interval (Sec)	Test Mode	Performance criteria
Voltage dips	100%	0.5	3	10	Mode 1/2/3	A
	100%	1	3	10	Mode 1/2/3	A
	30%	25	3	10	Mode 1/2/3	A
Voltage interruptions	100%	250	3	10	Mode 1/2/3	B

A: No degradation in the performance of the EUT was observed.

B: Stop charging during the test and self-recoverable after test.

Performance Note: For a 70 % residual voltage dip and voltage interruption tests, the following performance criteria apply: Lost functions can be recoverable by user or operator because the equipment is powered solely from the AC mains supply (without the use of a parallel battery back-up).

Note: operating mode include all modes of EMS in page 9.

17.5. PERFORMANCE

<input checked="" type="checkbox"/> Criteria A:	The apparatus continues to operate as intended. No degradation of performance or loss of function is allowed below a performance level specified by the manufacturer, when the apparatus is used as intended. In some cases the performance level may be replaced by a permissible loss of performance.
<input checked="" type="checkbox"/> Criteria B:	The apparatus continues to operate as intended after the test. No degradation of performance or loss of function is allowed below a performance level specified by the manufacturer, when the apparatus is used as intended. In some cases the performance level may be replaced by a permissible loss of performance. During the test, degradation of performance is however allowed.
<input type="checkbox"/> Criteria C:	Temporary loss of function is allowed, provided the functions self-recoverable or can be restored by the operation of controls.

Compliance **Not Compliance**

APPENDIX I: PHOTOGRAPHS OF TEST SETUP

LINE CONDUCTED EMISSION TEST SETUP

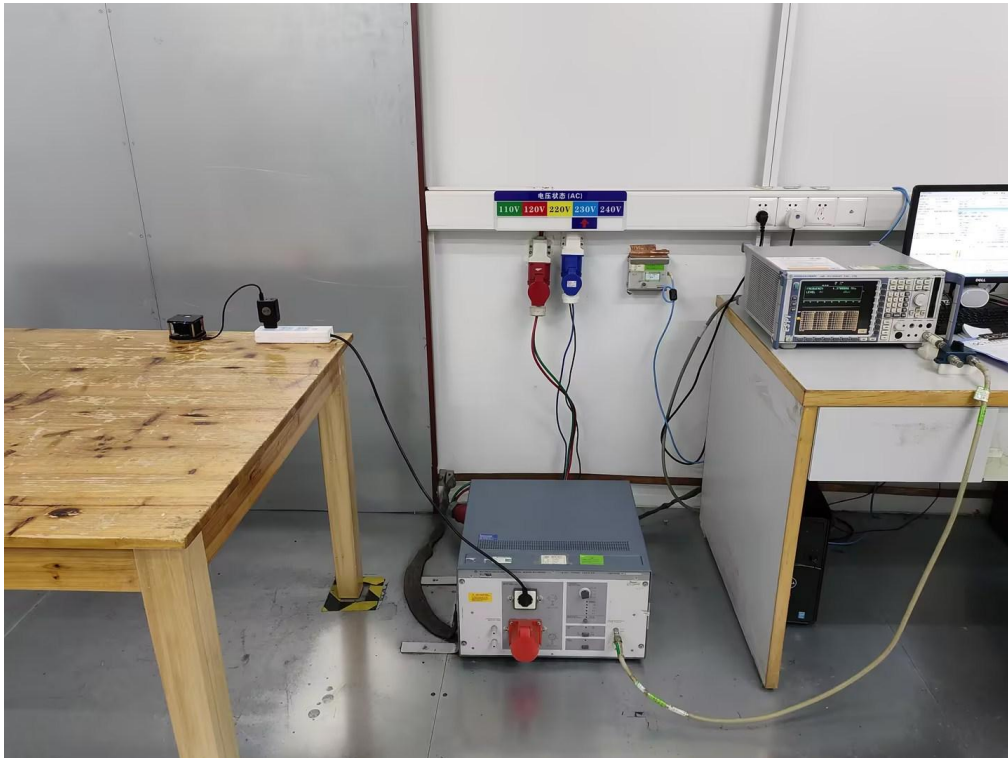

RADIATED EMISSION TEST SETUP (Below 1GHz)

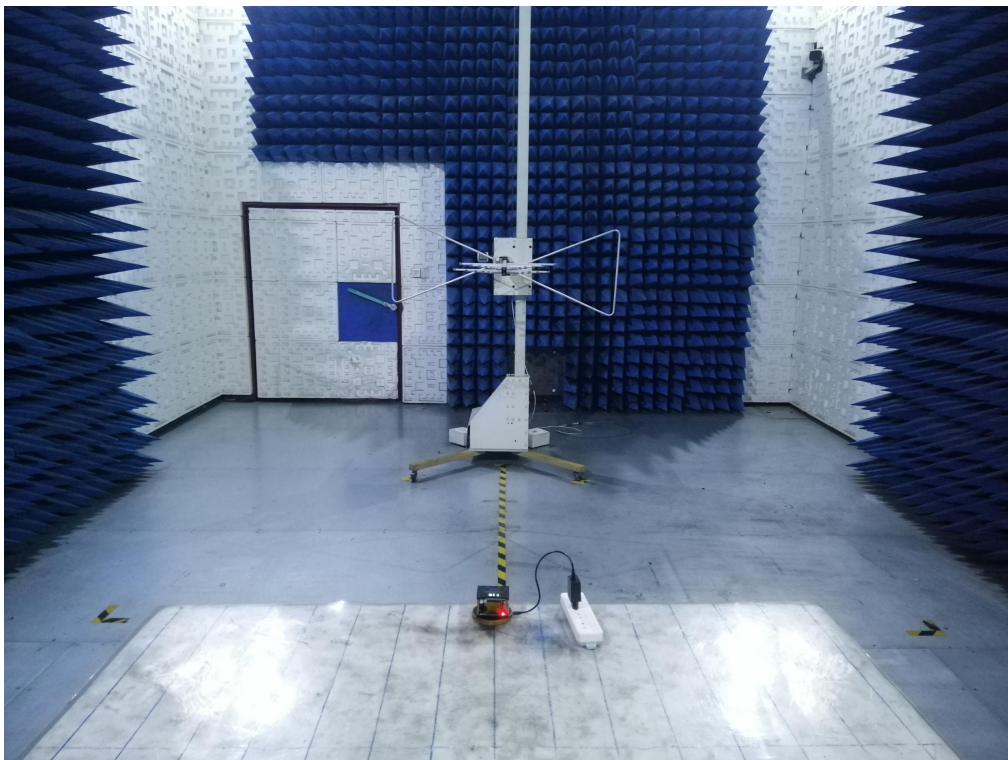

Any report having not been signed by authorized approver, or having been altered without authorization, or having not been stamped by the “Dedicated Testing/Inspection Stamp” is deemed to be invalid. Copying or excerpting portion of, or altering the content of the report is not permitted without the written authorization of AGC. The test results presented in the report apply only to the tested sample. Any objections to report issued by AGC should be submitted to AGC within 15days after the issuance of the test report. Further enquiry of validity or verification of the test report should be addressed to AGC by agc01@agccert.com.

Attestation of Global Compliance(Shenzhen)Co., Ltd
Attestation of Global Compliance(Shenzhen)Std & Tech Co., Ltd
Tel: +86-755 2523 4088 E-mail: agc@agccert.com Web: <http://www.agccert.com/>

EN61000-3-3 VOLTAGE FLUCTUATION AND FLICKER TEST SETUP



EN 61000-4-2 ESD TEST SETUP



Any report having not been signed by authorized approver, or having been altered without authorization, or having not been stamped by the "Dedicated Testing/Inspection Stamp" is deemed to be invalid. Copying or excerpting portion of, or altering the content of the report is not permitted without the written authorization of AGC. The test results presented in the report apply only to the tested sample. Any objections to report issued by AGC should be submitted to AGC within 15 days after the issuance of the test report. Further enquiry of validity or verification of the test report should be addressed to AGC by agc01@agccert.com.

EN 61000-4-3 RS TEST SETUP (Below 1GHz)

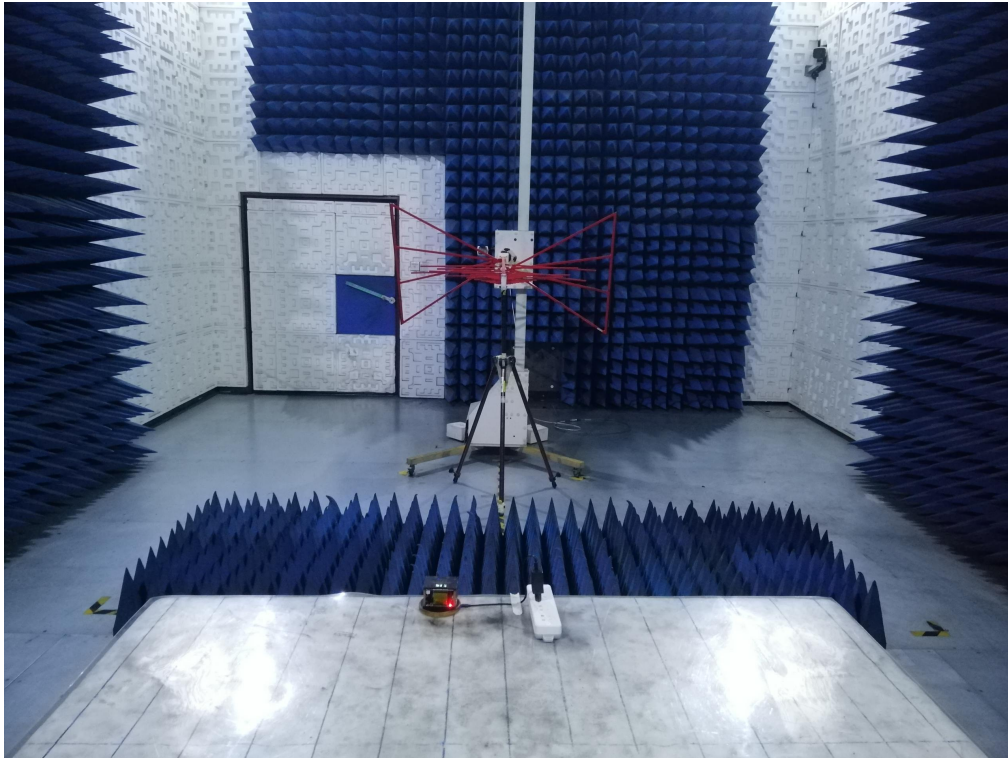

EN 61000-4-4/-5/-11EFT/SURGE/DIPS IMMUNITY TEST SETUP



Any report having not been signed by authorized approver, or having been altered without authorization, or having not been stamped by the “Dedicated Testing/Inspection Stamp” is deemed to be invalid. Copying or excerpting portion of, or altering the content of the report is not permitted without the written authorization of AGC. The test results presented in the report apply only to the tested sample. Any objections to report issued by AGC should be submitted to AGC within 15days after the issuance of the test report. Further enquiry of validity or verification of the test report should be addressed to AGC by agc01@agccert.com.

EN 61000-4-6 CS IMMUNITY TEST SETUP

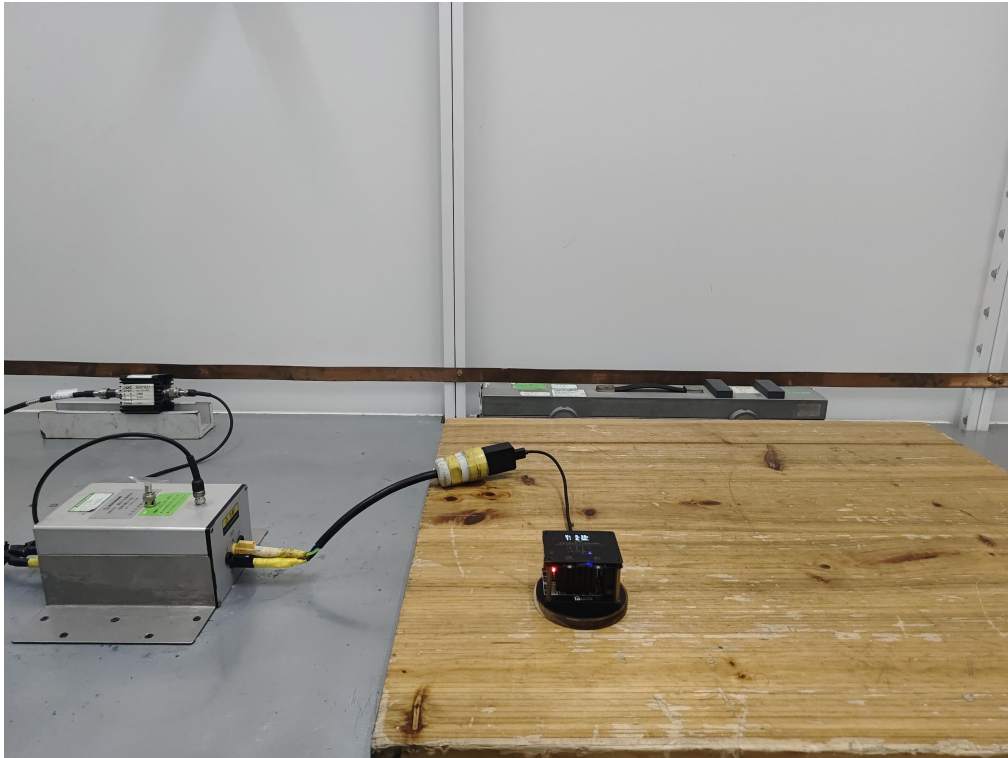

Any report having not been signed by authorized approver, or having been altered without authorization, or having not been stamped by the “Dedicated Testing/Inspection Stamp” is deemed to be invalid. Copying or excerpting portion of, or altering the content of the report is not permitted without the written authorization of AGC. The test results presented in the report apply only to the tested sample. Any objections to report issued by AGC should be submitted to AGC within 15days after the issuance of the test report. Further enquiry of validity or verification of the test report should be addressed to AGC by agc01@agccert.com.

APPENDIX II: PHOTOGRAPHS OF THE EUT

Refer to the Report No.: AGC05443231045AP01

----END OF REPORT----

Any report having not been signed by authorized approver, or having been altered without authorization, or having not been stamped by the “Dedicated Testing/Inspection Stamp” is deemed to be invalid. Copying or excerpting portion of, or altering the content of the report is not permitted without the written authorization of AGC. The test results presented in the report apply only to the tested sample. Any objections to report issued by AGC should be submitted to AGC within 15days after the issuance of the test report. Further enquiry of validity or verification of the test report should be addressed to AGC by agc01@agccert.com.

Attestation of Global Compliance(Shenzhen)Co., Ltd

Attestation of Global Compliance(Shenzhen)Std & Tech Co., Ltd

Tel: +86-755 2523 4088 E-mail: agc@agccert.com Web: <http://www.agccert.com/>



Conditions of Issuance of Test Reports

1. All samples and goods are accepted by the Attestation of Global Compliance (Shenzhen) Co., Ltd (the “Company”) solely for testing and reporting in accordance with the following terms and conditions. The company provides its services on the basis that such terms and conditions constitute express agreement between the company and any person, firm or company requesting its services (the “Clients”).
2. Any report issued by Company as a result of this application for testing services (the “Report”) shall be issued in confidence to the Clients and the Report will be strictly treated as such by the Company. It may not be reproduced either in its entirety or in part and it may not be used for advertising or other unauthorized purposes without the written consent of the Company. The Clients to whom the Report is issued may, however, show or send it, or a certified copy thereof prepared by the Company to its customer, supplier or other persons directly concerned. The Company will not, without the consent of the Clients, enter into any discussion or correspondence with any third party concerning the contents of the Report, unless required by the relevant governmental authorities, laws or court orders.
3. The Company shall not be called or be liable to be called to give evidence or testimony on the Report in a court of law without its prior written consent, unless required by the relevant governmental authorities, laws or court orders.
4. In the event of the improper use of the report as determined by the Company, the Company reserves the right to withdraw it, and to adopt any other additional remedies which may be appropriate.
5. Samples submitted for testing are accepted on the understanding that the Report issued cannot form the basis of, or be the instrument for, any legal action against the Company.
6. The Company will not be liable for or accept responsibility for any loss or damage however arising from the use of information contained in any of its Reports or in any communication whatsoever about its said tests or investigations.
7. Clients wishing to use the Report in court proceedings or arbitration shall inform the Company to that effect prior to submitting the sample for testing.
8. The Company is not responsible for recalling the electronic version of the original report when any revision is made to them. The Client assumes the responsibility to providing the revised version to any interested party who uses them.
9. Subject to the variable length of retention time for test data and report stored hereinto as otherwise specifically required by individual accreditation authorities, the Company will only keep the supporting test data and information of the test report for a period of six years. The data and information will be disposed of after the aforementioned retention period has elapsed. Under no circumstances shall we provide any data and information which has been disposed of after retention period. Under no circumstances shall we be liable for damage of any kind, including (but not limited to) compensatory damages, lost profits, lost data, or any form of special, incidental, indirect, consequential or punitive damages of any kind, whether based on breach of contract of warranty, tort (including negligence), product liability or otherwise, even if we are informed in advance of the possibility of such damages.

Any report having not been signed by authorized approver, or having been altered without authorization, or having not been stamped by the “Dedicated Testing/Inspection Stamp” is deemed to be invalid. Copying or excerpting portion of, or altering the content of the report is not permitted without the written authorization of AGC. The test results presented in the report apply only to the tested sample. Any objections to report issued by AGC should be submitted to AGC within 15days after the issuance of the test report. Further enquiry of validity or verification of the test report should be addressed to AGC by agc01@agccert.com.