



EMC TEST REPORT

Report No: FCS202312148E01

Applicant:	Mid Ocean Brands B.V.
Address:	7/F, Kings Tower, 111 King Lam Street, Cheung Sha Wan, Kowloon, Hong Kong.
Product Name:	Wireless speaker
Brand Name:	N/A
Model Name:	MO2210
Series Model:	N/A
Test Standard:	EN 55032:2015/A11:2020/A1:2020 EN 55035:2017/A11:2020 ETSI EN 301 489-1 V2.2.3 (2019-11) ETSI EN 301 489-17 V3.2.4 (2020-09)



TEST RESULT CERTIFICATION

Applicant's Name.....: Mid Ocean Brands B.V.

Address.....: 7/F, Kings Tower, 111 King Lam Street, Cheung Sha Wan, Kowloon, Hong Kong.

Manufacture's Name.....: Mid Ocean Brands B.V.

Address.....: 7/F, Kings Tower, 111 King Lam Street, Cheung Sha Wan, Kowloon, Hong Kong.

Product Description

Product Name.....: Wireless speaker

Brand Name: N/A

Model Name.....: MO2210

Series Model.....: N/A

Test Standards.....: EN 55032:2015/A11:2020/A1:2020
 EN 55035:2017/A1:2020
 ETSI EN 301 489-1 V2.2.3 (2019-11)
 ETSI EN 301 489-17 V3.2.4 (2020-09)

This device described above has been tested by FCS, and the test results show that the equipment under test (EUT) is in compliance with the 2014/53/EU RED Directive requirements. And it is applicable only to the tested sample identified in the report.
 This report shall not be reproduced except in full, without the written approval of FCS, this document may be altered or revised by FCS, personal only, and shall be noted in the revision of the document.

Date of Test.....:

Date (s) of performance of tests.: Dec 10, 2023 ~ Dec 15, 2023

Date of Issue.....: Dec 15, 2023

Test Result.....: Pass

Testing Engineer : Sam Wang
 (Sam Wang)

Technical Manager : Duke Qian
 (Duke Qian)

Authorized Signatory : Jack Wang
 (Jack Wang)





TABLE OF CONTENTS

1. TEST SUMMARY	5
1.1 TEST FACTORY	6
1.2 MEASUREMENT UNCERTAINTY	6
2. GENERAL INFORMATION	7
2.1 GENERAL DESCRIPTION OF THE EUT	7
2.2 DESCRIPTION OF THE TEST MODES	8
2.3 DESCRIPTION OF THE TEST SETUP	9
2.4 DESCRIPTION TEST PERIPHERAL AND EUT PERIPHERAL	10
2.5 MEASUREMENT INSTRUMENTS LIST	11
2.5.1 CONDUCTED TEST SITE	11
2.5.2 RADIATED TEST SITE	11
2.5.3 HARMONICS AND FLICKER	11
3. EMC EMISSION TEST	14
3.1 CONDUCTED EMISSION MEASUREMENT	14
3.2 RADIATED EMISSION MEASUREMENT	18
3.3 HARMONICS CURRENT	21
<i>Note: The above limits for all equipment except for lighting equipment having an active input power >75 W and no limits apply for equipment with an active input power up to and including 75W.</i>	<i>25</i>
3.4 VOLTAGE FLUCTUATION AND FLICKERS	26
4. EMC IMMUNITY TEST	28
4.1 STANDARD COMPLIANCE/SERVURITY LEVEL/CRITERIA	28
4.2 GENERAL PERFORMANCE CRITERIA	29
4.3 ELECTROSTATIC DISCHARGE IMMUNITY TEST (ESD)	30
4.4 RADIATED, RADIO-FREQUENCY, ELECTROMAGNETIC FIELD IMMUNITY TEST (RS)	33
4.5 ELECTRICAL FAST TRANSIENT (EFT)	36
4.6 SURGE TESTING	40
4.7 CONDUCTED RADIO FREQUENCY DISTURBANCES (CS)	42
4.8 POWER FREQUENCY MAGNETIC FIELD TESTING	47
4.9 VOLTAGE INTERRUPTION/DIPS TESTING (DIPS)	50
APPENDIX 1- TEST SETUP	52
※※※※※END OF THE REPORT※※※※※	53

**Revision History**

Rev.	Issue Date	Report No.	Effect Page	Contents
00	Dec 15, 2023	FCS202312148E01	N/A	Initial Issue

1. TEST SUMMARY

Test procedures according to the technical standards:

EMC Emission				
Standard	Test Item	Limit	Judgment	Remark
EN 55032:2015/A11:2020/A1:2020 ETSI EN 301 489-1 V2.2.3 (2019-11) ETSI EN 301 489-17 V3.2.4 (2020-09)	Conducted Emissions From The AC Mains Power Ports	Class B	PASS	
	Conducted Emissions From Asymmetric Mode	Class B	N/A	
	Conducted Differential Voltage Emissions	Class B	N/A	
	Radiated Emissions	Class B	PASS	
EN IEC 61000-3-2:2019/A1:2021	Harmonic Current Emission	Class A	PASS	
EN 61000-3-3:2013/A2:2021	Voltage Fluctuations & Flicker	-----	PASS	
EMC Immunity				
Section EN 55035:2017/A1 1:2020	Test Item	Performance Criteria	Judgment	Remark
EN 61000-4-2:2009	Electrostatic Discharge	B	PASS	
EN IEC 61000-4-3:2020	RF Electromagnetic Field	A	PASS	
EN 61000-4-4:2012	Fast Transients	B	PASS	
EN 61000-4-5:2014/A1:2017	Surges	B	PASS	
EN 61000-4-6:2013	Radio-frequency Common Mode / Conducted Susceptibility	A	PASS	
EN 61000-4-8:2010	Power Frequency Magnetic Field	A	PASS	
EN 61000-4-11:2004/A1:2017	Volt. Interruptions Volt. Dips	B / C / C	PASS	

Note: "N/A" denotes test is not applicable in this Test Report



1.1 TEST FACTORY

Company Name:	Dongguan Funas Testing Technology Co., Ltd.
Address:	Room 105, 1/F.. Baohao Technology Building 1, No.15, Gongye West Road.Songshan Lake Hi-Tech Industrial Area, Dongguan, Guangdong, China
Telephone:	+86-769-27280901
Fax:	+86-769-27280901
Laboray Accreditations	
FCC Test Firm Registration Number: 514908 CNAS Number: L15566 Designation number: CN0127 A2LA accreditation number: 5545.01 ISED Number: 25801	

1.2 MEASUREMENT UNCERTAINTY

The reported uncertainty of measurement $y \pm U$, where expended uncertainty U is based on a standard uncertainty multiplied by a coverage factor of $k=2$, providing a level of confidence of approximately **95** %.

A. Conducted Measurement:

Test Site	Method	Measurement Frequency Range	U, (dB)	NOTE
FCSC01	ANSI	9KHz ~ 150KHz	3.18	
		150 KHz ~ 30MHz	2.70	

B. Radiated Measurement:

Test Site	Method	Measurement Frequency Range	U, (dB)	NOTE
FCSC02	ANSI	9KHz ~ 30MHz	2.50	
		30MHz ~ 200MHz	3.43	
		200MHz ~ 1000MHz	3.57	
		1GHz ~ 6 GHz	4.13	

2. GENERAL INFORMATION

2.1 GENERAL DESCRIPTION OF THE EUT

Product Name	Wireless speaker	
Brand Name	N/A	
Model Name	MO2210	
Series Name	N/A	
Product Differences	N/A	
Product Description	The EUT is a Wireless speaker	
	Operation Frequency	2402~2480 MHz
	Modulation Type	BT(1Mbps): GFSK BT EDR(2Mbps): $\pi/4$ -DQPSK BT EDR(3Mbps): 8DPSK
	Number Of Channel	79CH
	Bit Rate of Transmitter	1Mbps/2Mbps/3Mbps
	Antenna Designation	PCB Antenna
	Antenna Gain(Peak)	1.7 dBi
Power Supply	Input: DC 5V=1A	
Battery	DC 3.7V	
Hardware version number	V1.0	
Software version number	V1.0	

2.2 DESCRIPTION OF THE TEST MODES

To investigate the maximum EMI emission characteristics generates from EUT, the test system was pre-scanning tested base on the consideration of following EUT operation mode or test configuration mode which possible have effect on EMI emission level. Each of these EUT operation mode(s) or test configuration mode(s) mentioned above was evaluated respectively.

Pretest Mode	Description
Mode 1	full load

Note: The test modes were carried out for all operation modes. Only worst case will be show in this report.

2.3 DESCRIPTION OF THE TEST SETUP

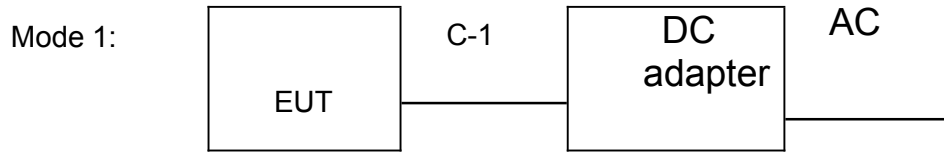

2.4 DESCRIPTION TEST PERIPHERAL AND EUT PERIPHERAL

The EUT has been tested as an independent unit together with other necessary accessories or support units. The following support units or accessories were used to form a representative test configuration during the tests.

Accessories equipment

Mode 1:

Item	Equipment	Mfr/Brand	Model/Type No.
1	Adapter	Xioami	AD652G

Auxiliary equipment

Mode 2:

Item	Equipment	Mfr/Brand	Model/Type No.
N/A	N/A	N/A	N/A

Cable

Mode 1:

Item	Type	Shielded Type	Ferrite Core	Length
C-1	N/A	N/A	N/A	N/A

Mode 2:

Item	Type	Shielded Type	Ferrite Core	Length
N/A	N/A	N/A	N/A	N/A

Note:

- (1) The support equipment was authorized by Declaration of Confirmation.
- (2) For detachable type I/O cable should be specified the length in cm in 『 Length 』 column.
- (3) “YES” means “shielded” “with core”; “NO” means “unshielded” “without core”.

2.5 MEASUREMENT INSTRUMENTS LIST

2.5.1 CONDUCTED TEST SITE

Kind of Equipment	Manufacturer	Type No.	Serial No.	Last Calibration	Calibrated Until
EMI Test Receiver	R&S	ESCI	101427	2023.08.29	2024.08.28
LISN	R&S	ENV216	101242	2023.08.29	2024.08.28
LISN	ETS	3810/2NM	00023625	2023.08.29	2024.08.28
Absorbing Clamp	R&S	MDS-21	100668	2023.08.29	2024.08.28
Universal Radio Communication Tester	R&S	CMW500	117239	2023.08.29	2024.08.28
CE Cable	N/A	C01	N/A	2023.08.29	2024.08.28
Temperature & Humidity	Mieo	HH660	N/A	2023.08.29	2024.08.28
Testing Software	EZ-EMC(Ver.03A1 CE)				

2.5.2 RADIATED TEST SITE

Kind of Equipment	Manufacturer	Type No.	Serial No.	Last Calibration	Calibrated Until
EMI Test Receiver	R&S	ESCI	101427	2023.08.29	2024.08.28
Bi-log Antenna	TESEQ	CBL6111D	34678	2023.08.29	2024.08.28
Horn Antenna	SCHWARZBECK	BBHA 9120D	9120D-1343	2023.08.29	2024.08.28
Pre-amplifier(1G-18G)	SKET	LNPA-01018G-45	SK2018080901	2023.08.29	2024.08.28
Pre-amplifier(0.1M-3GHz)	EM	EM330	060665	2023.08.29	2024.08.28
Spectrum Analyzer	Agilent	N9020A	MY49100060	2023.08.29	2024.08.28
Universal Radio Communication Tester	R&S	CMW500	117239	2023.08.29	2024.08.28
RE Cable (9K-1G)	N/A	R01	N/A	2023.08.29	2024.08.28
RE Cable (1G-18G)	N/A	R02	N/A	2023.08.29	2024.08.28
Temperature & Humidity	Mieo	HH660	N/A	2023.08.29	2024.08.28
Testing Software	EZ-EMC(Ver. 03A1 RE)				

2.5.3 HARMONICS AND FLICKER

Kind of Equipment	Manufacturer	Type No.	Serial No.	Last Calibration	Calibrated Until
Harmonic Voltage & Flicker	LAPLACE	AC 2000A	311217	2023.08.29	2024.08.28
AC Power Source	MTONI	PHF-5010	631169	2023.08.29	2024.08.28
Universal Radio Communication Tester	R&S	CMW500	117239	2023.08.29	2024.08.28
Temperature & Humidity	Mieo	HH660	N/A	2023.08.29	2024.08.28

Testing Software	HA-PC Link Version 3.03
------------------	-------------------------

2.5.4 ESD

Kind of Equipment	Manufacturer	Type No.	Serial No.	Last Calibration	Calibrated Until
Electrostatic Discharge Simulator	KZKUSUI	KES4021	LB003568	2023.08.29	2024.08.28
Universal Radio Communication Tester	R&S	CMW500	117239	2023.08.29	2024.08.28
Temperature & Humidity	N/A	WS1066	N/A	2023.08.29	2024.08.28

2.5.5 SURGE, EFT/BURST, VOLTAGE INTERRUPTION/DIPS

Kind of Equipment	Manufacturer	Type No.	Serial No.	Last Calibration	Calibrated Until
Surger Generator	HTEC	HCWG 10	152101	2023.08.29	2024.08.28
Surger Generator	HTEC	TC0MB4	152104	2023.08.29	2024.08.28
VOLTAGE DIPS & INTERRUPTIONS Generator	HTEC	HPFS 161P	143803	2023.08.29	2024.08.28
EFT/B Generator	HTEC	HEFT 51	143801	2023.08.29	2024.08.28
Universal Radio Communication Tester	R&S	CMW500	117239	2023.08.29	2024.08.28
Temperature & Humidity	Mieo	HH660	N/A	2023.08.29	2024.08.28

2.5.6 RS

Kind of Equipment	Manufacturer	Type No.	Serial No.	Last Calibration	Calibrated Until
Power Meter	Agilent	E4419B	QB4331226	2023.08.29	2024.08.28
Power Sensor	Hp	E9300A	US39210170	2023.08.29	2024.08.28
Power Sensor	Hp	E9300A	US39210476	2023.08.29	2024.08.28
Signal Generator	Agilent	N5181A	MY56144718	2023.08.29	2024.08.28
Power Amplifier	MICOTOP	MPA-80-1000-250	MPA1711489	2023.08.29	2024.08.28
Power Amplifier	MICOTOP	MPA-1000-3000-75	MPA1711488	2023.08.29	2024.08.28
Power Amplifier	MICOTOP	MPA-3000-6000-50	MPA1711490	2023.08.29	2024.08.28
RS Test Antenna (80-1GHz)	SCHWARZBECK	VULP 9118E	000999	2023.08.29	2024.08.28
RS Test Antenna (1G-10GHz)	SCHWARZBECK	STLP 9149	000648	2023.08.29	2024.08.28
Universal Radio Communication Tester	R&S	CMU200	177200	2023.08.29	2024.08.28

Universal Radio Communication Tester	R&S	CMW500	117239	2023.08.29	2024.08.28
Audio Analyzer	R&S	UPL	100689	2023.08.29	2024.08.28
Audio Breakthrough Shielding Box	SKET	SB_ABT/C35	N/A	2023.08.29	2024.08.28
Ear Simulator	SKET	AE_ABT/C35	N/A	2023.08.29	2024.08.28
Mouth Simulator	SKET	AM_ABT/C35	N/A	2023.08.29	2024.08.28
1KHz Standard Source	SKET	MSC_ABT/C35	N/A	2023.08.29	2024.08.28
Field Probe	Narda	EP601	611WX80261	2023.08.29	2024.08.28
Temperature & Humidity	Mieo	HH660	N/A	2023.08.29	2024.08.28
Testing Software	EMC-S V1.2.0.90				

2.5.7 INJECTION CURRENT

Kind of Equipment	Manufacturer	Type No.	Serial No.	Last Calibration	Calibrated Until
CS	SCHLODER	CDG-6000-25	126A1280/2014	2023.08.29	2024.08.28
CDN	SCHLODER	CDN-M2+3	A2210275/2014	2023.08.29	2024.08.28
EM Clamp	SCHLODER	EMCL-20	132A1283	2023.08.29	2024.08.28
Attenuator	Nemtest	ATT-6DB-100	A100W224	2023.08.29	2024.08.28
Universal Radio Communication Tester	R&S	CMW500	117239	2023.08.29	2024.08.28
Universal Radio Communication Tester	R&S	CMU200	177200	2023.08.29	2024.08.28
Audio Analyzer	R&S	UPL	100689	2023.08.29	2024.08.28
Audio Breakthrough Shielding Box	SKET	SB_ABT/C35	N/A	2023.08.29	2024.08.28
Ear Simulator	SKET	AE_ABT/C35	N/A	2023.08.29	2024.08.28
Mouth Simulator	SKET	AM_ABT/C35	N/A	2023.08.29	2024.08.28
1KHz Standard Source	SKET	MSC_ABT/C35	N/A	2023.08.29	2024.08.28
Temperature & Humidity	Mieo	HH660	N/A	2023.08.29	2024.08.28

2.5.8 PFMF

Kind of Equipment	Manufacturer	Type No.	Serial No.	Last Calibration	Calibrated Until
MF Generator	HTEC	HMFG-COMB	143903	2023.08.29	2024.08.28
Magnetic Field Coil	HTEC	HCOIL 100	143808	2023.08.29	2024.08.28
Universal Radio Communication Tester	R&S	CMW500	117239	2023.08.29	2024.08.28
Temperature & Humidity	Mieo	HH660	N/A	2023.08.29	2024.08.28

3. EMC EMISSION TEST

3.1 CONDUCTED EMISSION MEASUREMENT

3.1.1 REQUIREMENTS FOR CONDUCTED EMISSIONS FROM THE AC MAINS POWER PORTS OF THE CLASS A EQUIPMENT

FREQUENCY (MHz)	Coupling device	Detector type / bandwidth	Class A limits dB(μV)
0.15 - 0.5	AMN	Quasi Peak / 9 kHz	79
0.50 - 30			63
0.15 - 0.5	AMN	Average / 9 kHz	66
0.50 - 30			60

3.1.2 REQUIREMENTS FOR CONDUCTED EMISSIONS FROM THE AC MAINS POWER PORTS OF THE CLASS B EQUIPMENT

FREQUENCY (MHz)	Coupling device	Detector type / bandwidth	Class B limits dB(μV)
0.15 - 0.5	AMN	Quasi Peak / 9 kHz	66 - 56*
0.50 - 5			56
5 - 30			60
0.15 - 0.5	AMN	Average / 9 kHz	56 - 46*
0.50 - 5			46
5 - 30			50

Note:

- (1) The tighter limit applies at the band edges.
- (2) The limit of " * " marked band means the limitation decreases linearly with the logarithm of the frequency in the range.

The following table is the setting of the receiver

Receiver Parameters	Setting
Attenuation	10 dB
Start Frequency	0.15 MHz
Stop Frequency	30 MHz
IF Bandwidth	9 kHz

3.1.3 TEST PROCEDURE

- a. The EUT was placed 0.4 meters from the horizontal ground plane with EUT being connected to the power mains through a line impedance stabilization network (LISN). All other support equipment powered from additional LISN(s). The LISN provide 50 Ohm/ 50uH of coupling impedance for the measuring instrument.
- b. Interconnecting cables that hang closer than 40 cm to the ground plane shall be folded back and forth in the center forming a bundle 30 to 40 cm long.
- c. I/O cables that are not connected to a peripheral shall be bundled in the center. The end of the cable may be terminated, if required, using the correct terminating impedance. The overall length shall not exceed 1 m.
- d. For the actual test configuration, please refer to the related Item –EUT Test Photos.

3.1.4 TEST SETUP

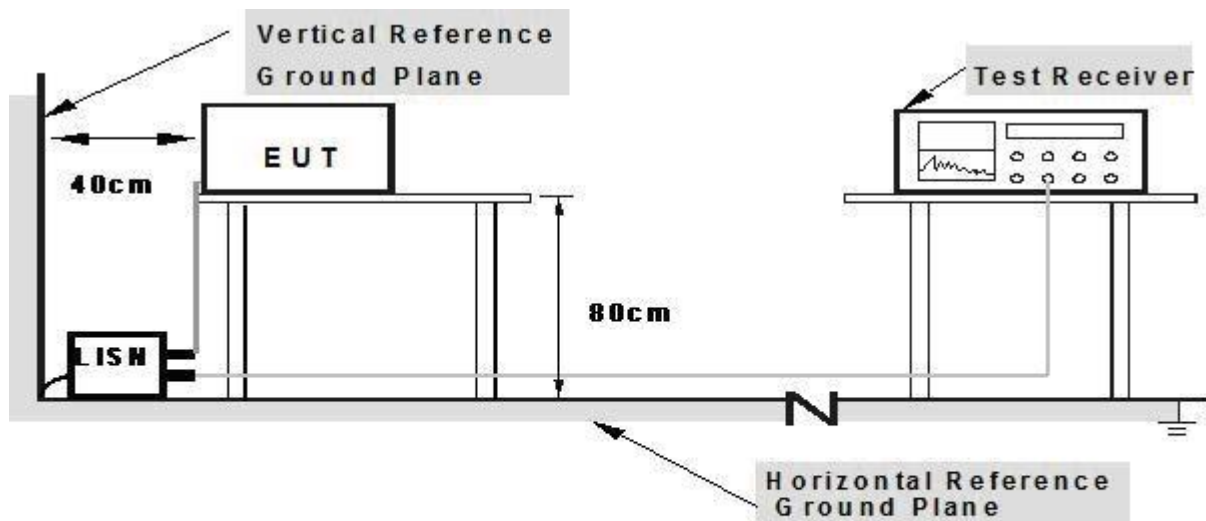

Note: 1. Support units were connected to second LISN.

2. Both of LISN s (AMN) are 80 cm from EUT and at least 80 from other units and other metal planes

3.1.5 EUT OPERATING CONDITIONS

The EUT tested system was configured as the statements of 2.3 Unless otherwise a special operating condition is specified in the following during the testing.

3.1.6 TEST RESULTS

Temperature:	25.3°C	Relative Humidity:	62%
Phase:	L	Test Mode:	Mode 1
Test Voltage:	AC 230V		

No.	Frequency (MHz)	Reading (dBUV)	Correct Factor(dB/m)	Result (dBUV/m)	Limit (dBUV/m)	Margin (dB)	Remark
1	0.1680	35.31	10.12	45.43	64.15	18.72	QP
2	0.1680	5.12	10.12	15.24	55.06	39.82	AVG
3	0.3570	21.21	10.02	31.23	58.52	27.29	QP
4	0.3570	14.05	10.02	24.07	48.80	24.73	AVG
5	1.1174	21.00	10.00	31.00	56.00	25.00	QP
6	1.1174	10.97	10.00	20.97	46.00	25.03	AVG
7	3.2235	15.97	9.93	25.90	56.00	30.10	QP
8	3.2235	1.05	9.93	10.98	46.00	35.02	AVG
9	7.0530	11.37	9.83	21.20	60.00	38.80	QP
10	7.0530	-0.26	9.83	9.57	50.00	40.43	AVG
11	13.9740	13.68	9.81	23.49	60.00	36.51	QP
12	13.9740	2.81	9.81	12.62	50.00	37.38	AVG

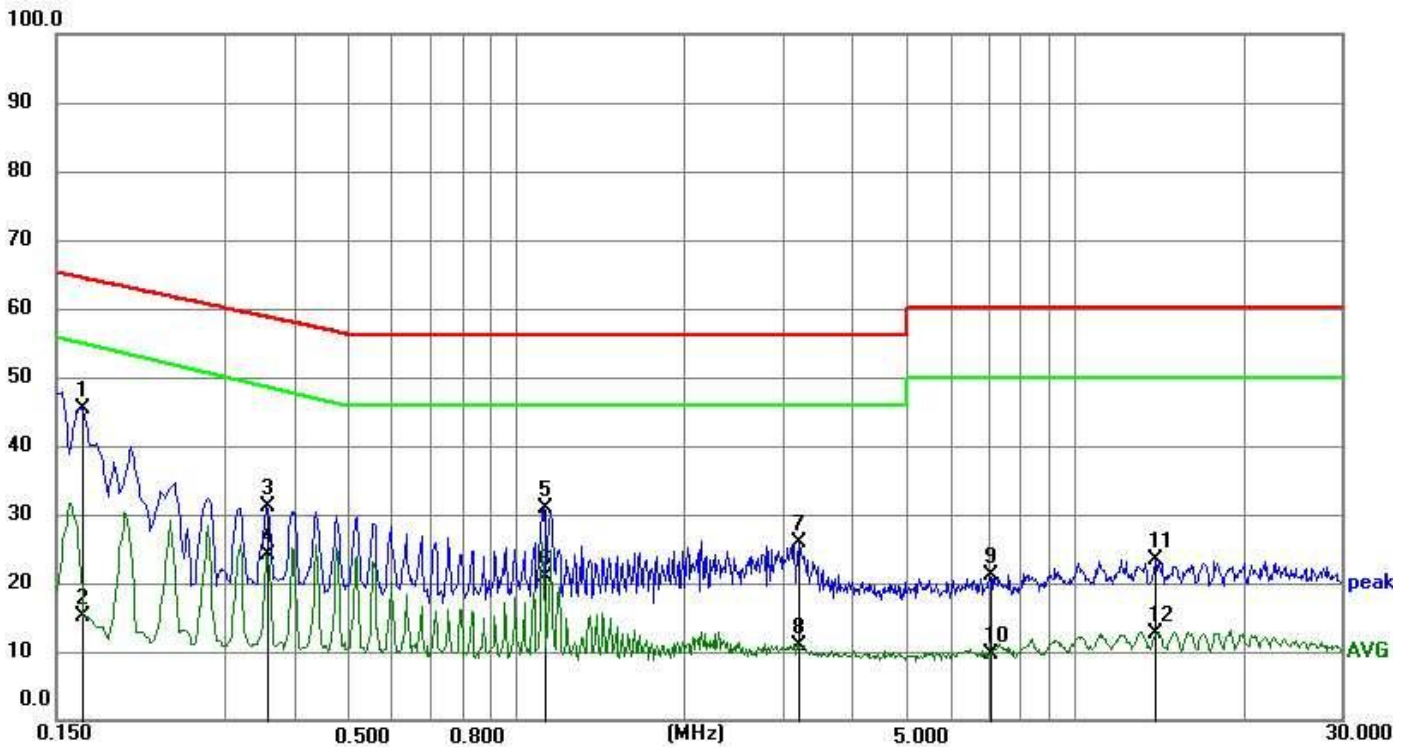

Remark:
1. All readings are Quasi-Peak and Average values.

Temperature:	25.3°C	Relative Humidity:	62%
Phase:	N	Test Mode:	Mode 1
Test Voltage:	AC 230V		

No.	Frequency (MHz)	Reading (dBuV)	Correct Factor(dB/m)	Result (dBuV/m)	Limit (dBuV/m)	Margin (dB)	Remark
1	0.2040	32.00	10.05	42.05	62.70	20.65	QP
2	0.2040	17.04	10.05	27.09	53.45	26.36	AVG
3	0.5595	19.18	10.00	29.18	56.00	26.82	QP
4	0.5595	7.43	10.00	17.43	46.00	28.57	AVG
5	1.1174	21.93	9.99	31.92	56.00	24.08	QP
6	1.1174	5.80	9.99	15.79	46.00	30.21	AVG
7	3.2370	16.40	9.93	26.33	56.00	29.67	QP
8	3.2370	1.54	9.93	11.47	46.00	34.53	AVG
9	11.0040	14.11	9.81	23.92	60.00	36.08	QP
10	11.0040	1.80	9.81	11.61	50.00	38.39	AVG
11	22.9155	13.46	9.99	23.45	60.00	36.55	QP
12	22.9155	1.82	9.99	11.81	50.00	38.19	AVG

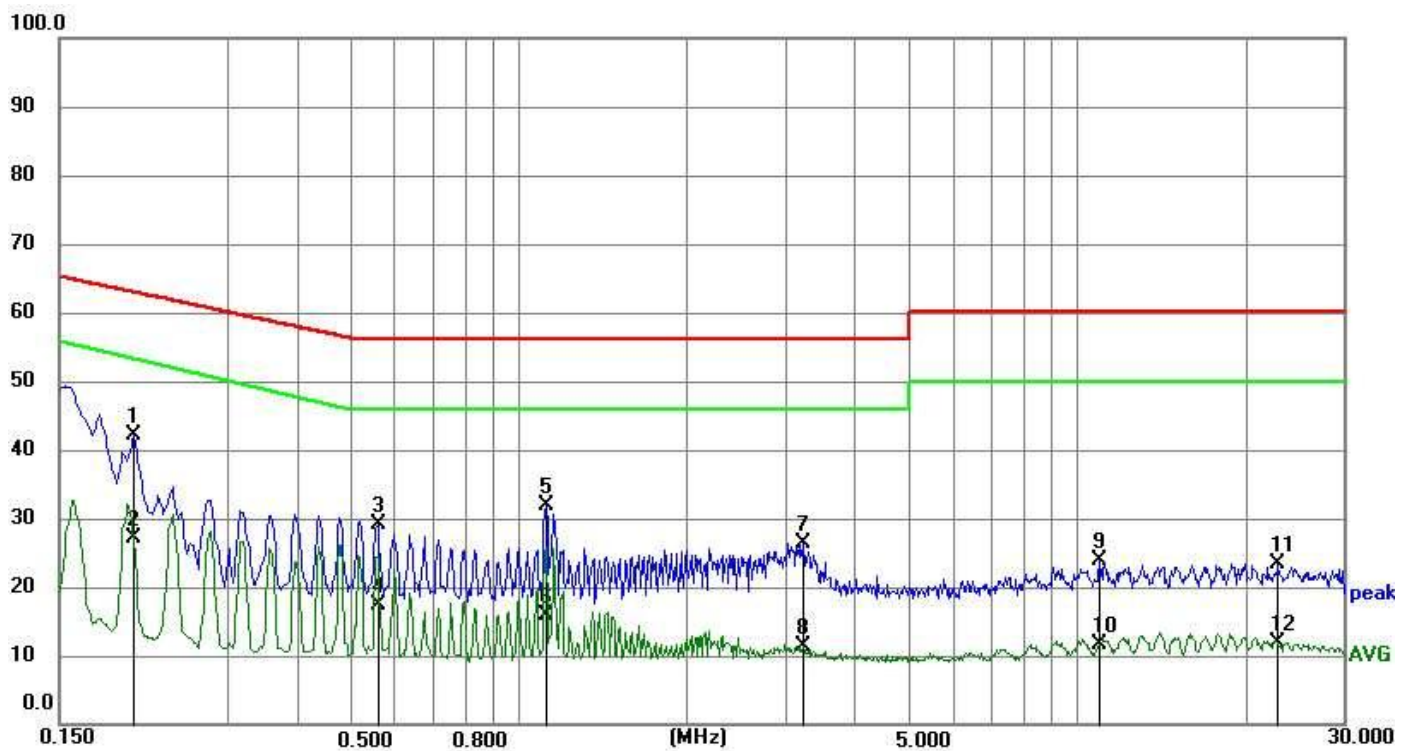

Remark:
All readings are Quasi-Peak and Average values.

3.2 RADIATED EMISSION MEASUREMENT

3.2.1 LIMITS OF THE RADIATED EMISSION MEASUREMENT

FREQUENCY (MHz)	Distance (m)	Detector type/ bandwidth	Class A	Class B
			dBuV/m	dBuV/m
30 - 230	3	Quasi peak/ 120 kHz	50	40
230 - 1000	3	Quasi peak/ 120 kHz	57	47
1000 - 3000	3	Peak /1 MHz	76	70
3000 - 6000	3	Peak /1 MHz	80	74
1000 - 3000	3	AV/1 MHz	56	50
3000 - 6000	3	AV/1 MHz	60	54

Notes:

- (1) The tighter limit applies at the band edges.
- (2) Emission level (dBuV/m) = 20log Emission level (uV/m).

3.2.3 TEST PROCEDURE

- a. The EUT was placed on the top of a rotating table 0.8 meters above the ground at a 3 meter semi-anechoic chamber room. The table was rotated 360 degrees to determine the position of the highest radiation.
- b. The EUT was set 3 meters away from the interference-receiving antenna, which was mounted on the top of a variable-height antenna tower.
- c. The height of antenna is varied from 1 meter to 4 meters above the ground to determine the maximum value of the field strength. Both horizontal and vertical polarizations of the antenna are set to make the measurement.
- d. For each suspected emission, the EUT was arranged to its worst case and then the antenna was tuned to heights from 1 meter to 4 meters and the rotatable table was turned from 0 degrees to 360 degrees to find the maximum reading.
- e. The test-receiver system was set to quasi-peak detect function and specified bandwidth with maximum hold mode when the test frequency is below 1GHz.
- f. For the actual test configuration, please refer to the related Item –EUT Test Photos.

3.2.4 TEST SETUP

(A) Radiated Emission Test Set-Up Frequency Below 1 GHz

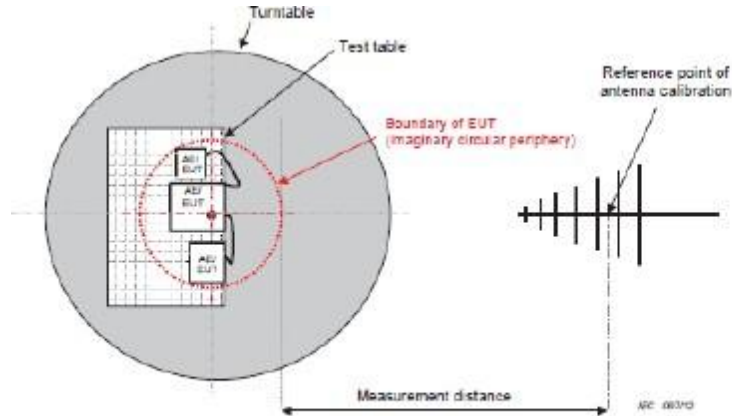

Figure C.1 – Measurement distance

(B) Radiated Emission Test Set-Up Frequency Above 1GHz

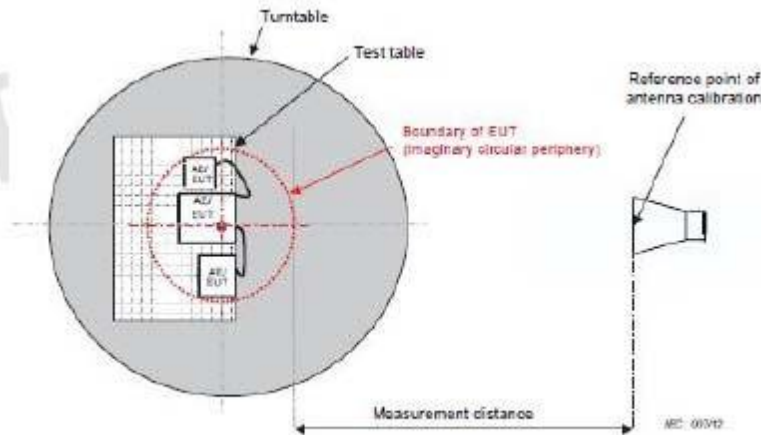

Figure C.1 – Measurement distance

3.2.5 EUT OPERATING CONDITIONS

The EUT tested system was configured as the statements of 2.3 Unless otherwise a special operating condition is specified in the following during the testing.

3.2.6 TEST RESULTS

Temperature:	24.4°C	Relative Humidity:	51%
Phase:	Horizontal	Test Mode:	Mode 1
Test Voltage:	DC3.7V		

No.	Frequency (MHz)	Reading (dBUV)	Correct Factor(dB/m)	Result (dBUV/m)	Limit (dBUV/m)	Margin (dB)	Remark
1	30.4238	29.37	-7.45	21.92	40.00	-18.08	QP
2	66.0342	31.73	-20.15	11.58	40.00	-28.42	QP
3	139.8508	48.83	-32.14	16.69	40.00	-23.31	QP
4	256.5211	66.64	-31.97	34.67	47.00	-12.33	QP
5	636.1340	58.58	-31.07	27.51	47.00	-19.49	QP
6	1000.0000	62.32	-30.60	31.72	47.00	-15.28	QP

Remark:

1. All readings are Quasi-Peak.
2. Margin = Result (Result = Reading + Factor) – Limit
3. Factor = Cable Loss + Antenna Factor – Amplifier Gain

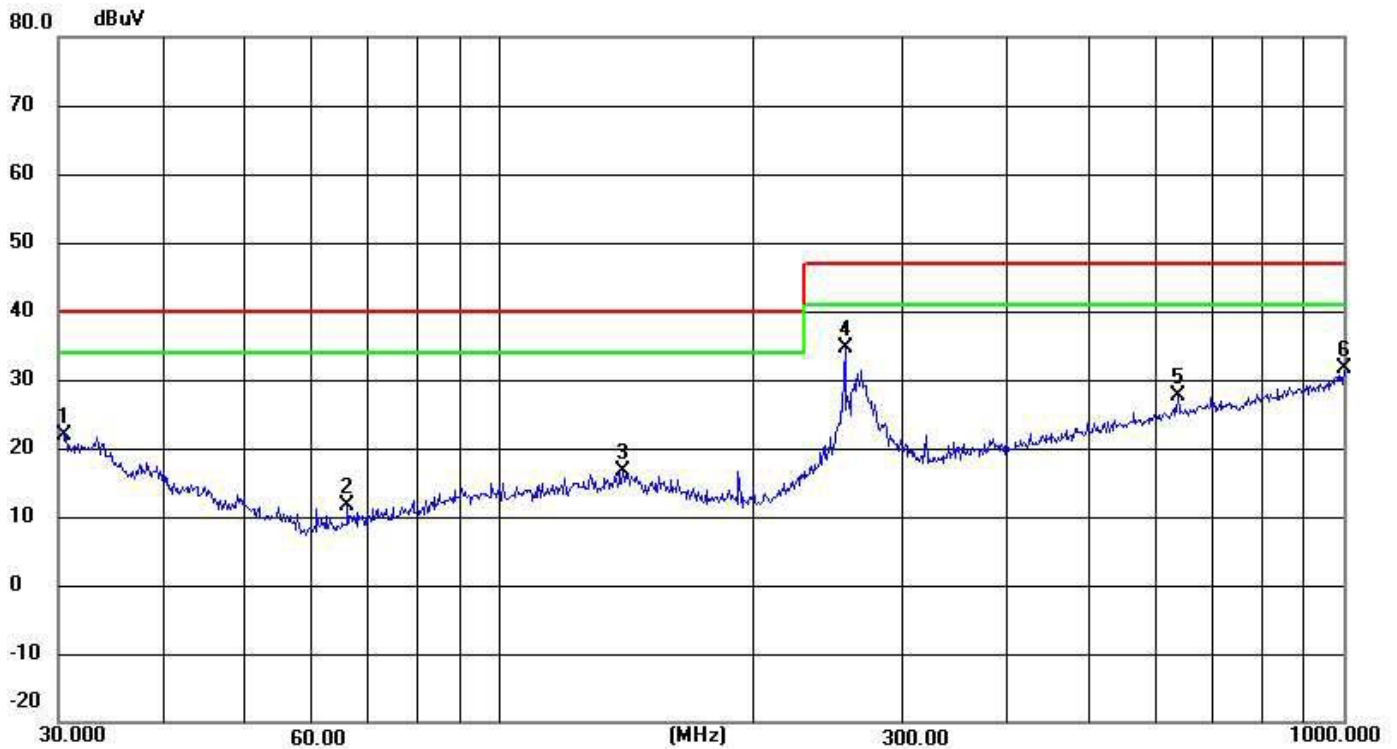

Temperature:	24.4°C	Relative Humidity:	51%
Phase:	Vertical	Test Mode:	Mode 1
Test Voltage:	DC 3.7V		

No.	Frequency (MHz)	Reading (dBuV)	Correct Factor(dB/m)	Result (dBuV/m)	Limit (dBuV/m)	Margin (dB)	Remark
1	30.8535	30.58	-7.73	22.85	40.00	-17.15	QP
2	55.2207	30.58	-19.43	11.15	40.00	-28.85	QP
3	138.3873	48.23	-32.14	16.09	40.00	-23.91	QP
4	256.5211	51.28	-31.97	19.31	47.00	-27.69	QP
5	556.7744	55.47	-31.21	24.26	47.00	-22.74	QP
6	1000.0000	61.59	-30.60	30.99	47.00	-16.01	QP

Remark:

1. All readings are Quasi-Peak.
2. Margin = Result (Result =Reading + Factor)–Limit
3. Factor= Cable Loss +Antenna Factor-Amplifier Gain

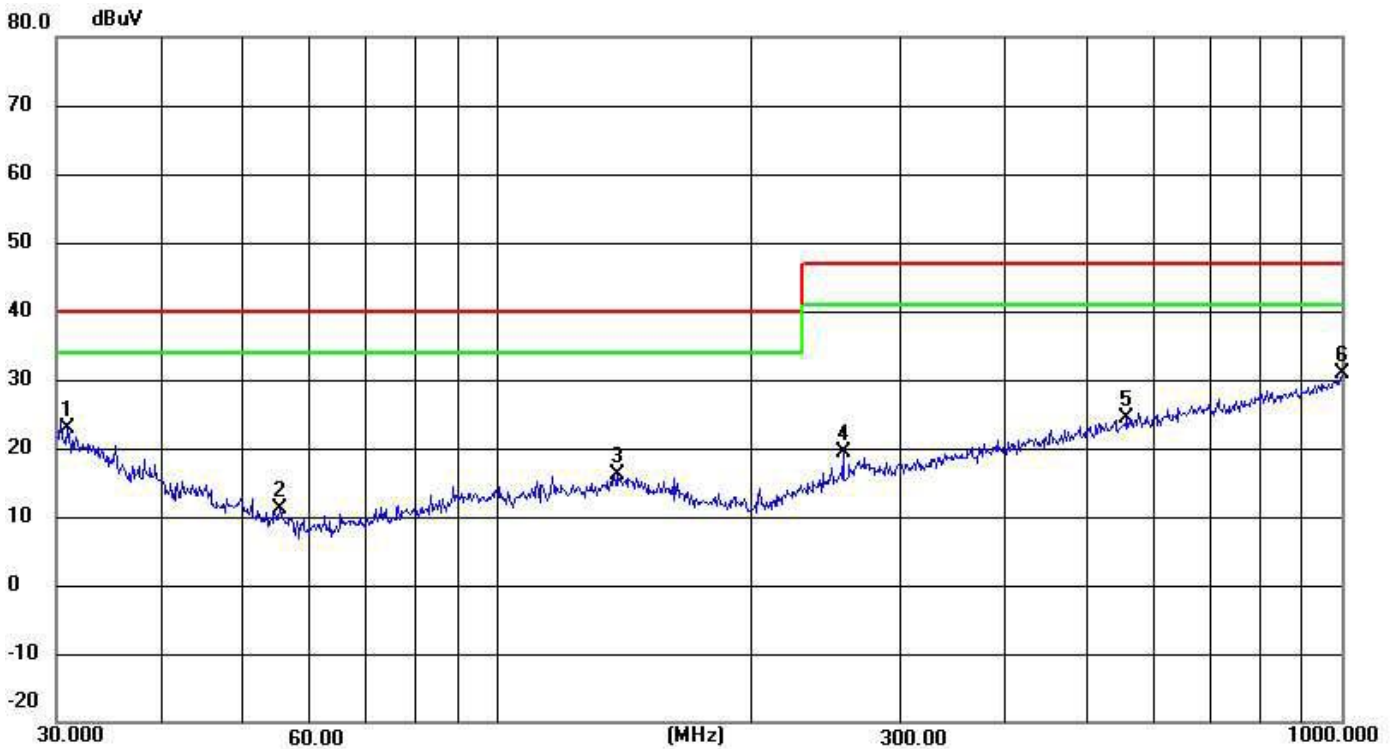

3.3 HARMONICS CURRENT

3.3.1 LIMITS OF THE HARMONICS CURRENT

IEC 555-2					
Table - I			Table - II		
Equipment Category	Harmonic Order n	Max. Permissible Harmonic Current (in Amperes)	Equipment Category	Harmonic Order n	Max. Permissible Harmonic Current (in Amperes)
Non Portable Tools or TV Receivers	Odd Harmonics		TV Receivers	Odd Harmonics	
	3	2.30		3	0.80
	5	1.14		5	0.60
	7	0.77		7	0.45
	9	0.40		9	0.30
	11	0.33		11	0.17
	13	0.21		13	0.12
	15 ≤ n ≤ 39	0.15 · 15/n		15 ≤ n ≤ 39	0.10 · 15/n
	Even Harmonics			Even Harmonics	
	2	1.08		2	0.30
	4	0.43		4	0.15
	8	0.30		DC	0.05
8 ≤ n ≤ 40	0.23 · 8/n				

EN 61000-3-2/IEC 61000-3-2					
Equipment Category	Max. Permissible Harmonic Current (in Amperes)	Equipment Category	Harmonic Order n	Max. Permissible Harmonic Current (in A)	Max. Permissible Harmonic Current (mA/w)
Class A	Same as Limits Specified in 4-2.1, Table - I, but only odd harmonics required	Class D	3	2.30	3.4
			5	1.14	1.9
			7	0.77	1.0
			9	0.40	0.5
			11	0.33	0.35
			13 ≤ n ≤ 39	see Table I	3.85/n
only odd harmonics required					

3.3.2 TEST PROCEDURE

a. The EUT was placed on the top of a wooden table 0.8 meters above the ground and operated to produce the maximum harmonic components under normal operating conditions.

b. The classification of EUT is according to section 5 of EN 61000-3-2. The EUT is classified as follows:

Class A: Balanced three-phase equipment, Household appliances excluding equipment as Class D, Tools excluding portable tools, Dimmers for incandescent lamps, audio equipment, equipment not specified in one of the three other classes.

Class B: Portable tools. Portable tools.; Arc welding equipment which is not professional equipment.

Class C: Lighting equipment.

Class D: Equipment having a specified power less than or equal to 600W of the following types: Personal computers and personal computer monitors and television receivers.

c. The correspondent test program of test instrument to measure the current harmonics emanated from EUT is chosen. The measure time shall be not less than the time necessary for the EUT to be exercised.

3.3.3 EUT OPERATING CONDITIONS

The EUT tested system was configured as the statements of 2.3 Unless otherwise a special operating condition is specified in the following during the testing.

3.3.4 TEST SETUP

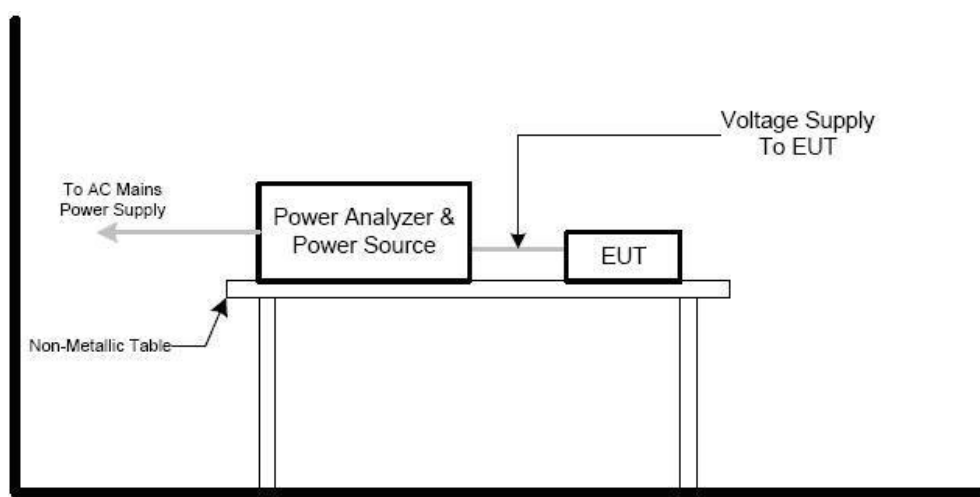

3.3.5 TEST RESULTS

Temperature:	26°C	Relative Humidity:	45%
Test Voltage:	AC 230V		

Harmonic Spectrum

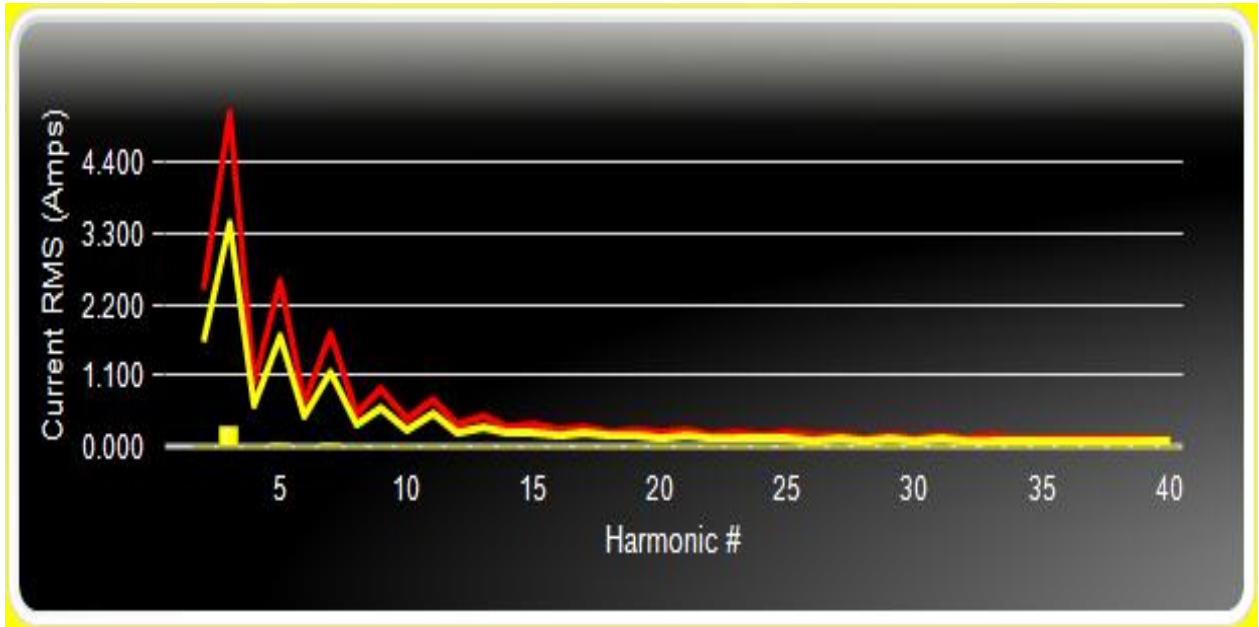

Voltage & Current Waveform

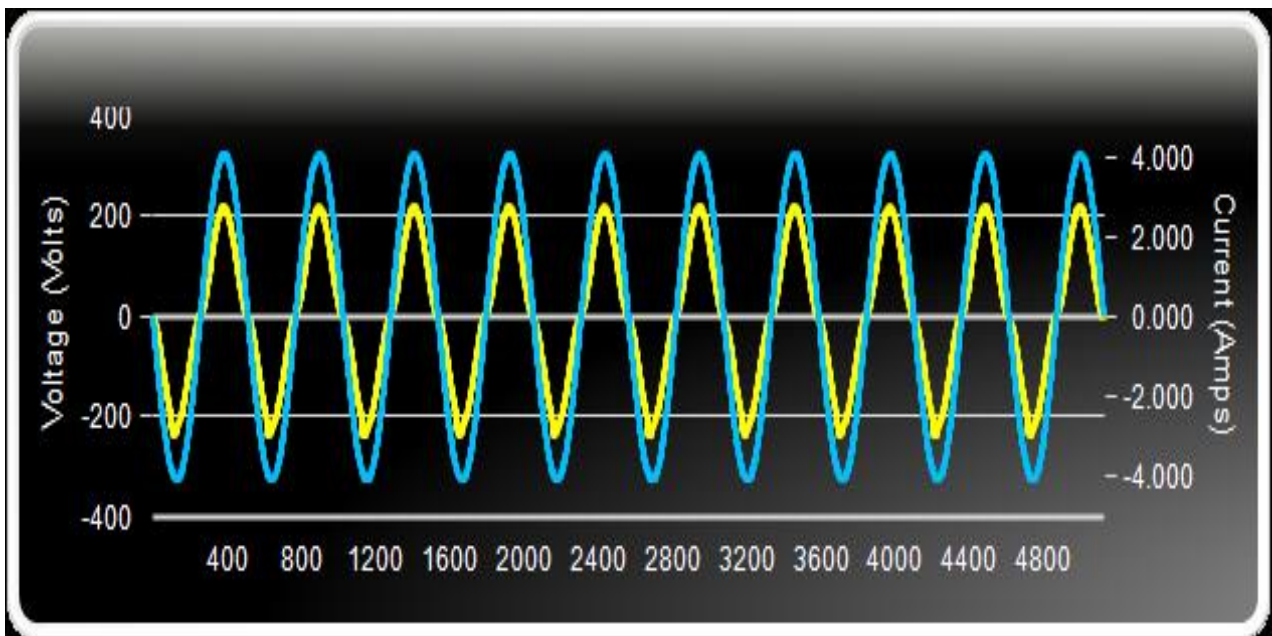

2-9kHz Current Harmonic Spectrum

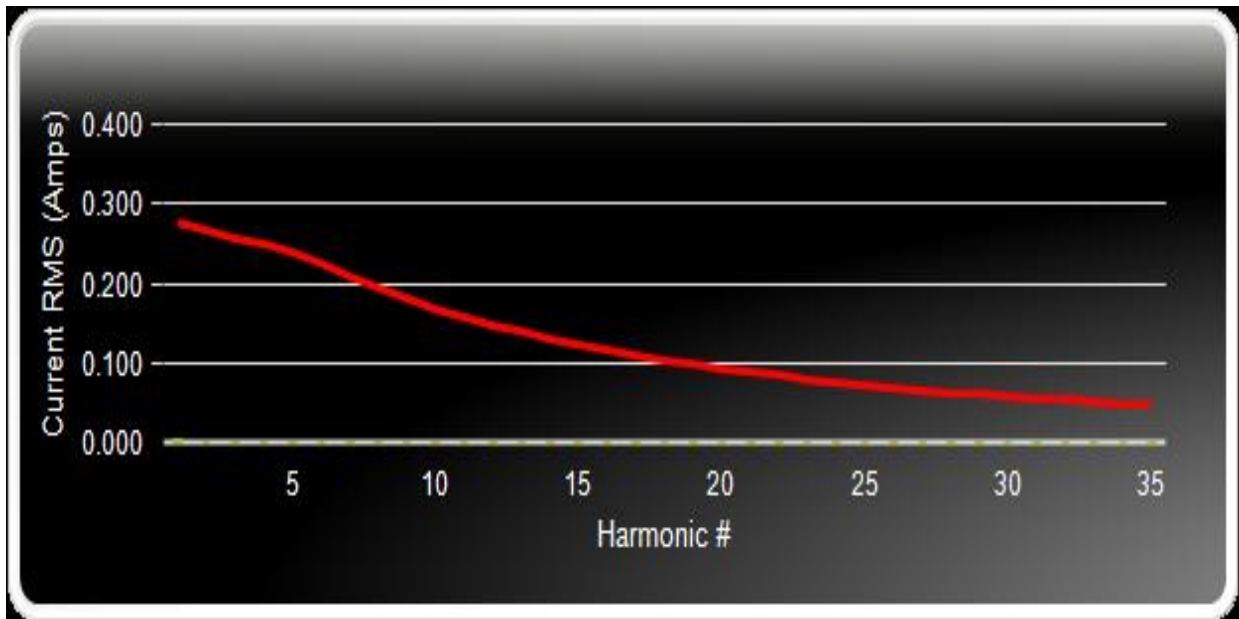

2-9kHz Voltage Harmonic Spectrum

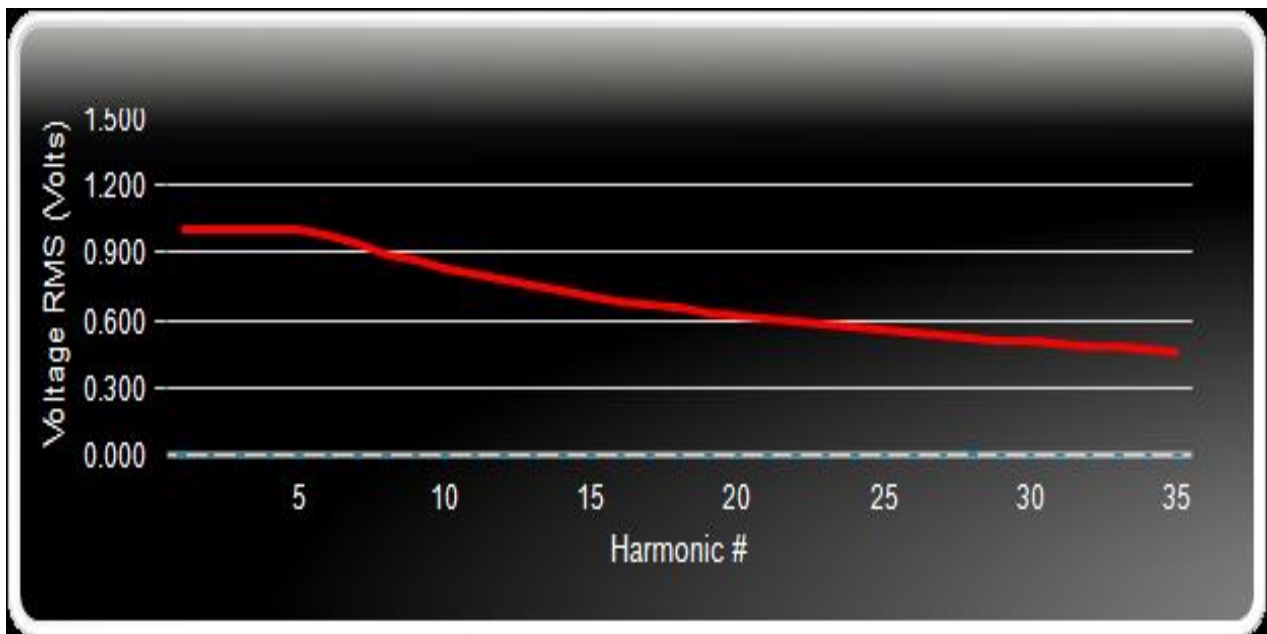

Note: The above limits for all equipment except for lighting equipment having an active input power > 75 W and no limits apply for equipment with an active input power up to and including 75W.

3.4 VOLTAGE FLUCTUATION AND FLICKERS

3.4.1 LIMITS OF THE VOLTAGE FLUCTUATION AND FLICKERS

Tests	Measurement Value	Limit	Descriptions
	IEC555-3	IEC/EN 61000-3-3	
P _{st}	≤ 1.0, T _p = 10 min.	≤ 1.0, T _p = 10 min.	Short Term Flicker Indicator
P _{lt}	N/A	≤0.65, T _p =2 hr.	Long Term Flicker Indicator
T _{dt(s)}	≤ 3%	≤ 3.3%	Relative Steady-State V-Chang
d _{max} (%)	≤ 4%	≤ 4%	Maximum Relative V-Chang
d _c (%)	N/A	≤ 3.3% for > 500ms	Relative V-change Characteristic

3.4.2 TEST PROCEDURE

a. Fluctuation and Flickers Test:

Tests was performed according to the Test Conditions/Assessment of Voltage Fluctuations specified in Clause 5.0/6.0 of IEC555-3 and/or Clause 6.0/4.0 of IEC/EN 61000-3-3 depend on which standard adopted for compliance measurement.

b. All types of voltage fluctuation in this report are assessed by direct measurement using flicker-meter.

3.4.3 EUT OPERATING CONDITIONS

The EUT tested system was configured as the statements of 2.3 Unless otherwise a special operating condition is specified in the following during the testing.

3.4.4 TEST SETUP

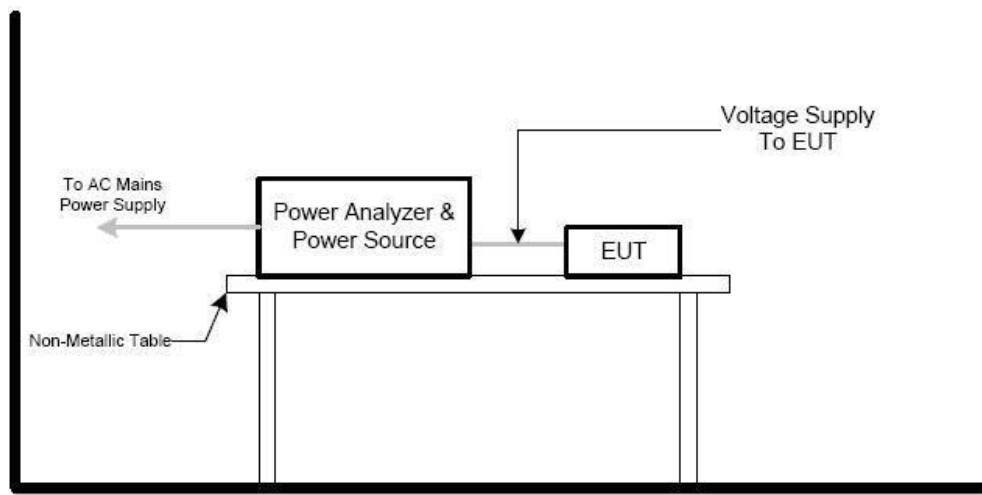

3.4.5 TEST RESULTS

Temperature:	23.9 °C	Relative Humidity:	54%
Test Voltage:	AC 230V		

Test Parameter	Measurement Value	Limit	Remarks
P _{st}	0.00	1.0	Pass
P _{It}	--	0.65	--
T _{dt(s)}	0.00	0.5	Pass
d _{max} (%)	0.00%	4%	Pass
d _c (%)	0.00%	3.3%	Pass

4. EMC IMMUNITY TEST

4.1 STANDARD COMPLIANCE/SERVIRITY LEVEL/CRITERIA

Tests Standard No.	TEST SPECIFICATION	Test Mode Test Ports	Perform. Criteria
1. ESD IEC/EN 61000-4-2	8KV air discharge 4KV contact discharge	Direct Mode	B
	4KV HCP discharge 4KV VCP discharge	Indirect Mode	B
2. RS IEC/EN 61000-4-3	80 MHz - 1000 MHz,1800MHz,2600MHz,3500MHz,50 00MHz, 1000Hz, 80%, AM modulated	Enclosure	A
3. EFT/Burst IEC/EN 61000-4-4	5/50ns Tr/Th 5KHz Repetition Freq.	Power Supply Port	B
	5/50ns Tr/Th 5KHz Repetition Freq.	CTL/Signal Data Line Port	B
4. Surges IEC/EN 61000-4-5	1.2/50(8/20) Tr/Th us	L-N	B
	1.2/50(8/20) Tr/Th us	L-PE N-PE	B
5. Injected Current IEC/EN 61000-4-6	0.15 MHz to 80 MHz, 1000Hz 80 % , AM Modulated 150Ω source impedance	CTL/Signal Port	A
	0.15 MHz to 80 MHz, 1000Hz 80 % , AM Modulated 150Ω source impedance	AC Power Port	A
	0.15 MHz to 80 MHz, 1000Hz 80 % , AM Modulated 150Ω source impedance	DC Power Port	A
6. Power Frequency Magnetic Field IEC/EN 61000-4-8	50 Hz,	Enclosure	A
7. Volt. Interruptions Volt. Dips IEC/EN 61000-4-11	Voltage dip 100%	AC Power Port	B
	Voltage dip 30%		C
	Interruption 100%		C

4.2 GENERAL PERFORMANCE CRITERIA

According to EN 55035 standard, the general performance criteria as following:

<p>Criterion A</p>	<p>The equipment shall continue to operate as intended without operator intervention. No degradation of performance, loss of function or change of operating state is allowed below a performance level specified by the manufacturer when the equipment is used as intended. The performance level may be replaced by a permissible loss of performance. If the minimum performance level or the permissible performance loss is not specified by the manufacturer, then either of these may be derived from the product description and documentation, and by what the user may reasonably expect from the equipment if used as intended.</p>
<p>Criterion B</p>	<p>During the application of the disturbance, degradation of performance is allowed. However, no unintended change of actual operating state or stored data is allowed to persist after the test.</p> <p>After the test, the equipment shall continue to operate as intended without operator intervention; no degradation of performance or loss of function is allowed, below a performance level specified by the manufacturer, when the equipment is used as intended. The performance level may be replaced by a permissible loss of performance.</p> <p>If the minimum performance level (or the permissible performance loss), or recovery time, is not specified by the manufacturer, then either of these may be derived from the product description and documentation, and by what the user may reasonably expect from the equipment if used as intended.</p>
<p>Criterion C</p>	<p>Loss of function is allowed, provided the function is self-recoverable, or can be restored by the operation of the controls by the user in accordance with the manufacturer's instructions. A reboot or re-start operation is allowed.</p> <p>Information stored in non-volatile memory, or protected by a battery backup, shall not be lost.</p>

4.2.1 GENERAL PERFORMANCE CRITERIA TEST SETUP

The EUT tested system was configured as the statements of 2.3 Unless otherwise a special operating condition is specified in the following during the testing.

4.3 ELECTROSTATIC DISCHARGE IMMUNITY TEST (ESD)

4.3.1 TEST SPECIFICATION

Basic Standard:	IEC/EN 61000-4-2
Discharge Impedance:	330 ohm / 150 pF
Required Performance:	B
Discharge Voltage:	Air Discharge: 2KV/4KV/8KV (Direct) Contact Discharge: 2KV/4KV (Direct/Indirect)
Polarity:	Positive & Negative
Number of Discharge:	Air Discharge: min. 20 times at each test point Contact Discharge: min. 200 times in total 20 times at each test point
Discharge Mode:	Single Discharge
Discharge Period:	1 second minimum

4.3.2 TEST PROCEDURE

The test generator necessary to perform direct and indirect application of discharges to the EUT in the following manners:

- a. Electrostatic discharges were applied only to those points and surfaces of the EUT that are accessible to users during normal operation
The test was performed with at least ten single discharges on the pre-selected points in the most sensitive polarity.

The time interval between two successive single discharges was at least 1 second.

The ESD generator was held perpendicularly to the surface to which the discharge was applied and the return cable was at least 0.2 meters from the EUT.

Contact discharges were applied to the non-insulating coating, with the pointed tip of the generator penetrating the coating and contacting the conducting substrate.

Air discharges were applied with the round discharge tip of the discharge electrode approaching the EUT as fast as possible (without causing mechanical damage) to touch the EUT. After each discharge, the ESD generator was removed from the EUT and re-triggered for a new single discharge. The test was repeated until all discharges were complete.

Vertical Coupling Plane (VCP):

The coupling plane, of dimensions 0.5m x 0.5m, is placed parallel to, and positioned at a distance 0.1m from, the EUT, with the Discharge Electrode touching the coupling plane.

The four faces of the EUT will be performed with electrostatic discharge.

Horizontal Coupling Plane (HCP):

The coupling plane is placed under to the EUT. The generator shall be positioned vertically at a distance of 0.1m from the EUT, with the Discharge Electrode touching the coupling plane.

The four faces of the EUT will be performed with electrostatic discharge.

- b. Air discharges at insulation surfaces of the EUT.

It was at least ten single discharges with positive and negative at the same selected point.

4.3.3 TEST SETUP

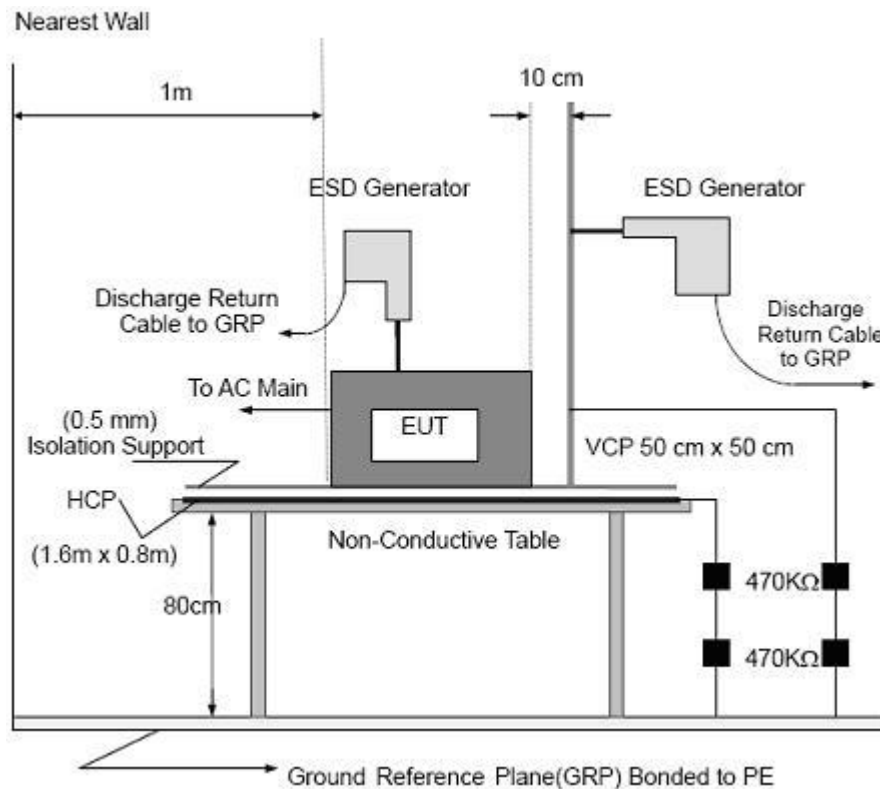

Note:

TABLE-TOP EQUIPMENT

The configuration consisted of a wooden table 0.8 meters high standing on the Ground Reference Plane. The GRP consisted of a sheet of aluminum at least 0.25mm thick. A Horizontal Coupling Plane (1.6m x 0.8m) was placed on the table and attached to the GRP by means of a cable with 940kΩ total impedance. The equipment under test, was installed in a representative system as described in section 7 of IEC /EN 61000-4-2, and its cables were placed on the HCP and isolated by an insulating support of 0.5mm thickness. A distance of 0.8-meter minimum was provided between the EUT and the walls of the laboratory and any other metallic structure.

FLOOR-STANDING EQUIPMENT

The equipment under test was installed in a representative system as described in section 7 of IEC/EN 61000-4-2, and its cables were isolated from the Ground Reference Plane by an insulating support of 0.1 meter thickness. The GRP was consisted of a sheet of aluminum that is at least 0.25mm thick, and extended at least 0.5 meters from the EUT on all sides.

4.3.4 TEST RESULTS

Temperature:	23.9°C	Relative Humidity:	56%
Pressure:	1020.1hPa	Test Voltage:	DC 3.7V
Test Mode:	Mode1		

Discharge Level	Polarity	Test Points	Contact Discharge	Air Discharge	Criterion	Test Result
4	+/-	VCP/HCP	NOTE	N/A	B	PASS
2,4	+/-	Green Dot	Note	N/A	B	PASS
2,4,8	+/-	Red Dot	N/A	NOTE	B	PASS

Note: The EUT function was correct during the test.
 Red Dot —Air Discharged
 Green Dot —Contact Discharged

4.4 RADIATED, RADIO-FREQUENCY, ELECTROMAGNETIC FIELD IMMUNITY TEST (RS)

4.4.1 TEST SPECIFICATION

Basic Standard:	IEC/EN 61000-4-3
Required Performance:	A
Frequency Range:	80 MHz - 6000 MHz
Field Strength:	3 V/m
Modulation:	1kHz Sine Wave, 80%, AM Modulation
Frequency Step:	1 % of fundamental
Polarity of Antenna:	Horizontal and Vertical
Test Distance:	3 m
Antenna Height:	1.5 m
Dwell Time:	1.5×10^{-3} decade/s

4.4.2 TEST PROCEDURE

- a. The testing was performed in a fully anechoic chamber. The transmit antenna was located at a distance of 3 meters from the EUT.
- b. The frequency range is swept from 80 MHz to 1000 MHz, 1800 MHz, 2600 MHz, 3500 MHz, 5000 MHz, with the signal 80% amplitude modulated with a 1kHz sine-wave. The rate of sweep did not exceed 1.5×10^{-3} decade/s, where the frequency range is swept incrementally, the step size was 1% of preceding frequency value.
- c. The dwell time at each frequency shall be not less than the time necessary for the EUT to be able to respond.
- e. The test was performed with the EUT exposed to both vertically and horizontally polarized fields on each of the four sides.

4.4.3 TEST SETUP

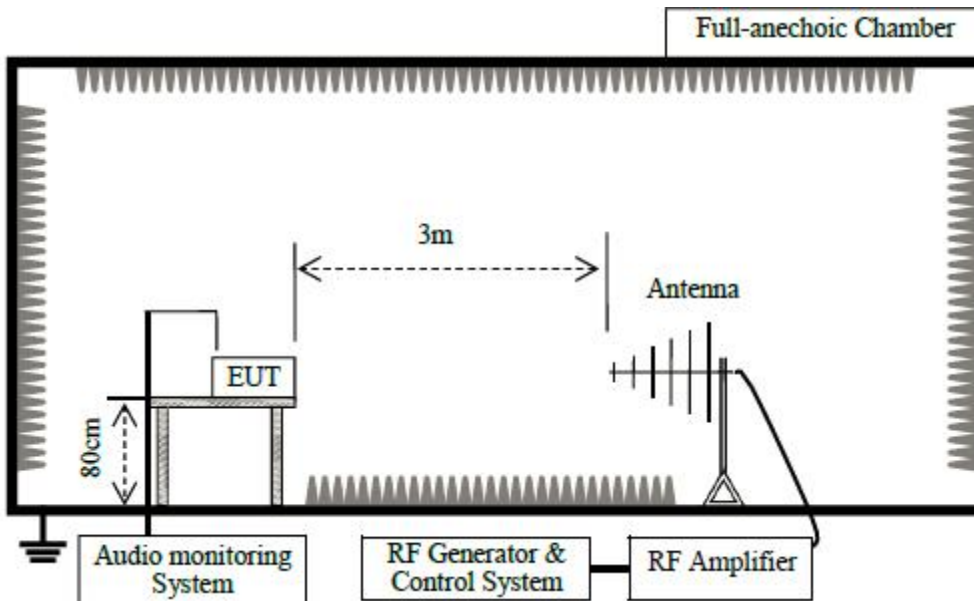

Note:

TABLE-TOP EQUIPMENT

The EUT installed in a representative system as described in section 7 of IEC/EN 61000-4-3 was placed on a non-conductive table 0.8 meters in height. The system under test was connected to the power and signal wire according to relevant installation instructions.

FLOOR-STANDING EQUIPMENT

The EUT installed in a representative system as described in section 7 of IEC/EN 61000-4-3 was placed on a non-conductive wood support 0.1 meters in height. The system under test was connected to the power and signal wire according to relevant installation instructions.

For Audio output function use below setting

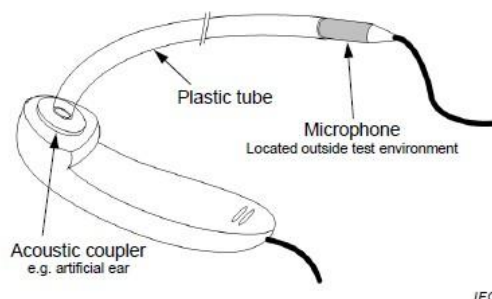

NOTE 1 The microphone is connected via the cable to a suitable amplifier.

NOTE 2 This setup is suitable for radiated immunity testing. See G.6.3

Figure G.5 – Example test setup for on-ear acoustic measurements, microphone located away from earpiece transducer

4.4.4 TEST RESULTS

Temperature:	23.9°C	Relative Humidity:	54%
Test Voltage:	DC 3.7V	Test Mode:	Mode1

Frequency Range (MHz)	RF Field Position	R.F. Field Strength	Azimuth	Perform. Criteria	Results	Judgment
80MHz - 6000MHz	H / V	3 V/m (rms) AM Modulated 1000Hz, 80%	Front	A	A	PASS
			Rear			
			Left			
			Right			
			Rear			
			Left			
			Right			

For the acoustic level of the demodulated audio limits

Frequency(MHz)	dB(SPL)
80 to 1 000	75

Note: According to EN 55035: 2017, Annex A, A.2 Applicability, the EUT belongs to Group 2. And then according to EN 55035: 2017, Annex A, A.4 Modified test levels and performance criteria, Table A.2 – Modified test levels for performance criterion A for the broadcast reception function, no test requirements apply to this EUT.

4.5 ELECTRICAL FAST TRANSIENT (EFT)

4.5.1 TEST SPECIFICATION

Basic Standard:	IEC/EN 61000-4-4
Required Performance:	B
Test Voltage:	Power Line: 1 KV Signal/Control Line: 0.5 KV DC network power port:0.5KV
Polarity:	Positive & Negative
Impulse Frequency:	5 kHz
Impulse Wave shape :	5/50 ns
Burst Duration:	15ms
Burst Period:	300ms
Test Duration:	Not less than 1 min.

4.5.2 TEST PROCEDURE

The EUT and support equipment, are placed on a table that is 0.8 meter&0.1 meter above a metal ground plane measured 1m*1m min .

The ground reference plane shall be a metallic sheet (copper or aluminum) of 0.25 mm minimum thickness; other metallic materials may be used, but they shall have at least 0.65 mm minimum thickness.

The other condition need as following manners:

- c. The length of power cord between the coupling device and the EUT should not exceed 1 meter.
- d. Both positive and negative polarity discharges were applied.
- e. The duration time of each test sequential was 1 minute

4.5.3 TEST SETUP

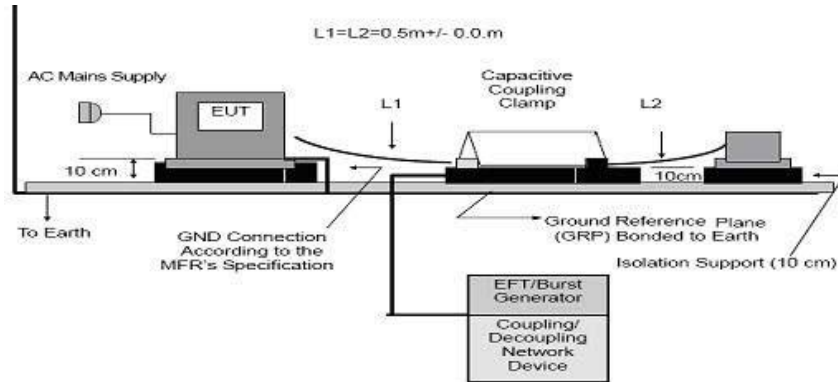
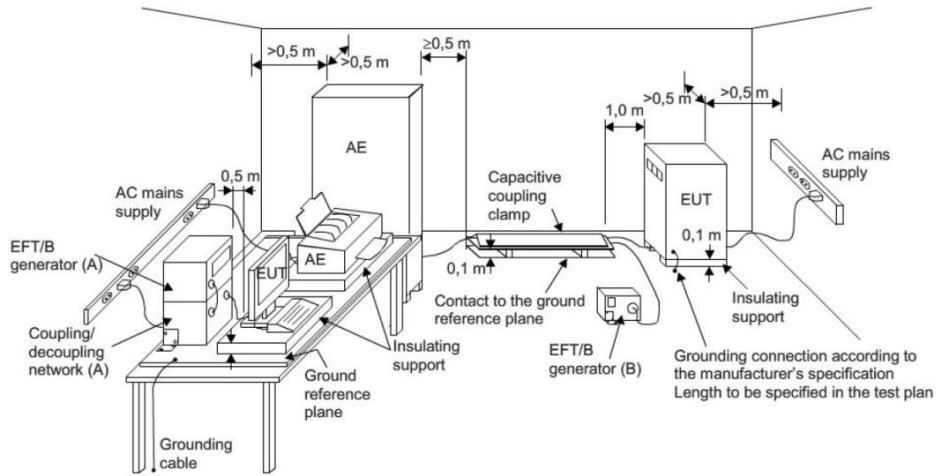

Note:

TABLE-TOP EQUIPMENT

Table-top equipment and equipment normally mounted on ceilings or walls as well as built-in equipment shall be tested with the EUT located (0.1 ± 0.01) m above the ground reference plane. Testing of large table-top equipment or multiple systems can be performed on the floor; maintaining the same distances as for the test setup of table-top equipment.

The test generator and the coupling/decoupling network shall be bonded to the ground reference plane.

The ground reference plane shall be a metallic sheet (copper or aluminum) of 0.25 mm minimum thickness; other metallic materials may be used, but they shall have at least 0.65 mm minimum thickness.

The minimum size of the ground reference plane is 0.8 m x 1 m. The actual size depends on the dimensions of the EUT.

The ground reference plane shall project beyond the EUT by at least 0.1 m on all sides.

The ground reference plane shall be connected to the earth (PE) for safety reasons.

The EUT shall be arranged and connected to satisfy its functional requirements, according to the equipment installation specifications.

The minimum distance between the EUT and all other conductive structures (including the generator, AE and the walls of a shielded room), except the ground reference plane, shall be more than 0.5 m.

All cables to the EUT shall be placed on the insulation support 0.1 m above the ground reference plane. Cables not subject to electrical fast transients shall be routed as far as possible from the cable under test to minimize the coupling between the cables.

The EUT shall be connected to the earth system in accordance with the manufacturer's installation specifications; no additional earth connections are allowed.

The connection impedance of the coupling/decoupling network earth cables to the ground reference plane and all connectors shall provide a low inductance.

Either a direct coupling network or a capacitive clamp shall be used for the application of the test voltages. The test voltages shall be coupled to all of the EUT ports in turn including those between two units of equipment involved in the test, unless the length of the interconnecting cable makes it impossible to test.

FLOOR-STANDING EQUIPMENT

When using the coupling clamp, the minimum distance between the coupling plates and all other conductive surfaces (including the generator), except the ground reference plane beneath the coupling clamp and beneath the EUT, shall be at least 0.5 m.

The distance between any coupling devices and the EUT shall be ($0.5 - 0/+0.1$) m for tabletop equipment testing, and (1.0 ± 0.1) m for floor standing equipment, unless otherwise specified in product standards. When it is not physically possible to apply the distances mentioned above, other distances can be used and shall be recorded in the test report.

The cable between the EUT and the coupling device, if detachable, shall be as short as possible to comply with the requirements of this clause. If the manufacturer provides a cable exceeding the distance between the coupling device and the point of entry of the EUT, the excess length of this cable shall be bundled and situated at a distance of 0.1 m above the ground reference plane. When a capacitive clamp is used as a coupling device, the excess cable length shall be bundled at the AE side.

Parts of the EUT with interconnecting cables of a length less than 3 m, which are not tested, shall be placed on the insulating support. The parts of the EUT shall have a distance of 0.5 m between them. Excess cable length shall be bundled.

4.5.4 TEST RESULTS

Temperature:	23.9°C	Relative Humidity:	54%
Test Voltage:	AC 230V	Test Mode:	Mode1

Coupling Line		Test level	Perform. Criteria	Results	Judgment
AC line	L	±1KV	B	B	Pass
	N	±1KV		B	Pass
	PE	N/A		N/A	N/A
	L+N	±1KV		B	Pass
	L+PE	N/A		N/A	N/A
	N+PE	N/A		N/A	N/A
	L+N+PE	N/A		N/A	N/A
DC network power port Line		N/A		N/A	N/A
Signal Line		N/A		N/A	N/A

Note: 1) N/A - denotes test is not applicable in this test report.

4.6 SURGE TESTING

4.6.1 TEST SPECIFICATION

Basic Standard:	IEC/EN 61000-4-5
Required Performance:	B
Wave-Shape:	Combination Wave 1.2/50us Open Circuit Voltage
Test Voltage:	Power line ~ line to line: 1 KV line to ground: 2KV Telecommunication line: 0.5KV DC network power port:0.5KV
Surge Input/Output:	L-N, L-PE, N-PE
Generator Source:	(L-N)2 ohm between networks
Impedance:	(L-PE, N-PE)12 ohm between network and ground
Polarity:	Positive/Negative
Phase Angle:	0°/90°/180°/270°
Pulse Repetition Rate:	1 time / min. (maximum)
Number of Tests:	5 positive and 5 negative at selected points

4.6.2 TEST PROCEDURE

- a. For EUT power supply:
- b. The surge is to be applied to the EUT power supply terminals via the capacitive coupling network. Decoupling networks are required in order to avoid possible adverse effects on equipment not under test that may be powered by the same lines, and to provide sufficient decoupling impedance to the surge wave. The power cord between the EUT and the coupling/decoupling networks shall be 2meters in length (or shorter).
- c. For test applied to unshielded unsymmetrically operated interconnection lines of EUT:
- d. The surge is applied to the lines via the capacitive coupling. The coupling /decoupling networks shall not influence the specified functional conditions of the EUT. The interconnection line between the EUT and the coupling/decoupling networks shall be 2 meters in length (or shorter).

4.6.3 TEST SETUP

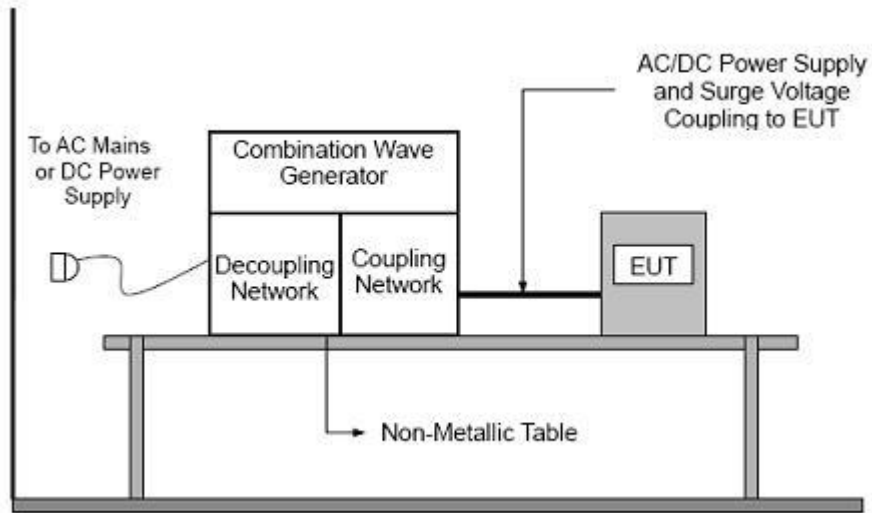

4.6.4 TEST RESULTS

Temperature:	23.9°C	Relative Humidity:	54%
Test Voltage:	AC 230V	Test Mode:	Mode1

Coupling Line		Test level	Perform. Criteria	Results	Judgment
AC line	L-N	±1KV	B	B	Pass
	L-PE	N/A		N/A	N/A
	N-PE	N/A		N/A	N/A
DC network power port		N/A		N/A	N/A
Signal Line		N/A		N/A	N/A

Note: 1) N/A - denotes test is not applicable in this test report.

4.7 CONDUCTED RADIO FREQUENCY DISTURBANCES (CS)

4.7.1 TEST SPECIFICATION

Basic Standard:	IEC/EN 61000-4-6
Required Performance:	A
Frequency Range:	0.15 MHz - 80 MHz
Field Strength:	0.15 MHz - 80 MHz, 3V.
Modulation:	1kHz Sine Wave, 80%, AM Modulation
Frequency Step:	1 % of fundamental
Dwell Time:	1.5×10^{-3} decade/s

4.7.2 TEST PROCEDURE

The EUT shall be tested within its intended operating and climatic conditions.

The test shall be performed with the test generator connected to each of the coupling and decoupling devices in turn, while the other non-excited RF input ports of the coupling devices are terminated by a 50-ohm load resistor.

The frequency range was swept from 150 kHz to 80 MHz using the signal level established during the setting process and with a disturbance signal of 80 % amplitude. The signal was modulated with a 1 kHz sine wave, pausing to adjust the RF signal level or the switch coupling devices as necessary. The sweep rate was 1.5×10^{-3} decades/s. Where the frequency range is swept incrementally, the step size was 1 % of preceding frequency value from 150 kHz to 80 MHz.

The dwell time at each frequency was less than the time necessary for the EUT to be exercised, and able to respond. Sensitive frequencies such as clock frequency (ies) and harmonics or frequencies of dominant interest, was analyzed separately.

Attempts were made to fully exercise the EUT during testing, and to fully interrogate all exercise modes selected for susceptibility.

4.7.3 TEST SETUP

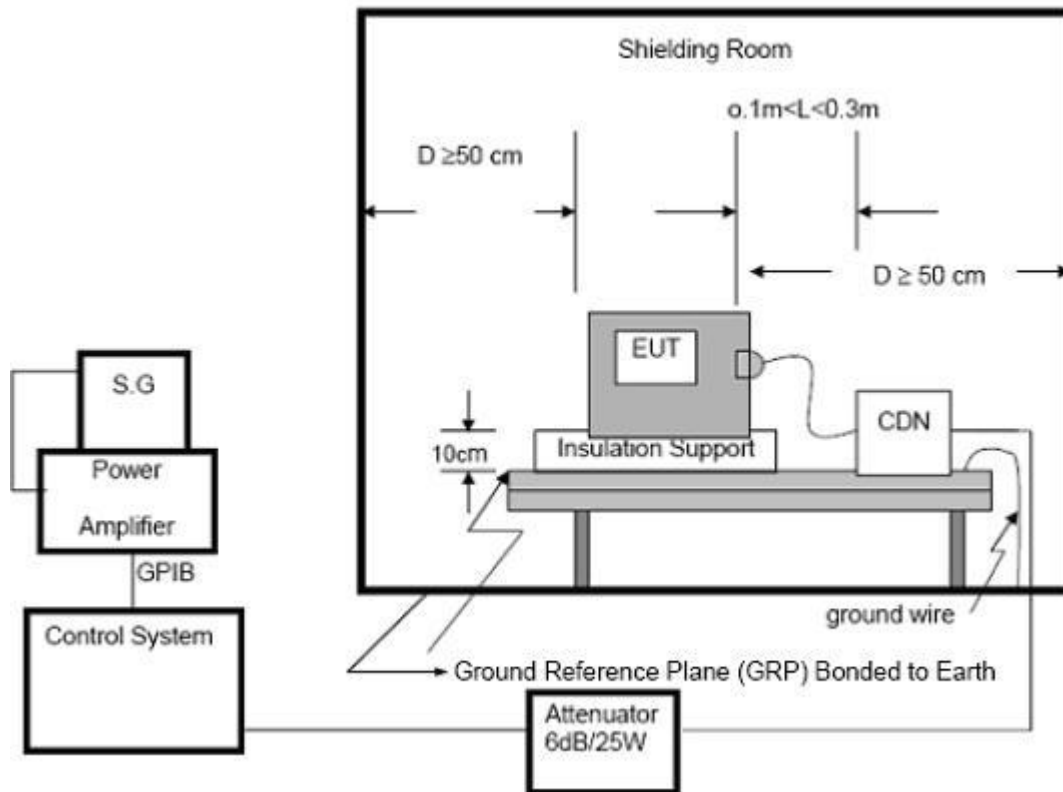

NOTE:

FLOOR-STANDING EQUIPMENT

The equipment to be tested is placed on an insulating support of 0.1 meters height above a ground reference plane. All relevant cables shall be provided with the appropriate coupling and decoupling devices at a distance between 0.1 meters and 0.3 meters from the projected geometry of the EUT on the ground reference plane.

For Audio output function use below setting

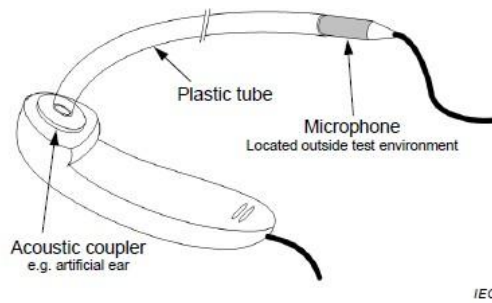

NOTE 1 The microphone is connected via the cable to a suitable amplifier.

NOTE 2 This setup is suitable for radiated immunity testing. See G.6.3

Figure G.5 – Example test setup for on-ear acoustic measurements, microphone located away from earpiece transducer

4.7.4 TEST RESULTS

Temperature:	23.9°C	Relative Humidity:	54%
Test Voltage:	AC 230V	Test Mode:	Mode1

Test Ports (Mode)	Freq. Range MHz)	Field Strength	Perform. Criteria	Results	Judgment
Input/ Output AC. Power Port	0.15 –80 MHZ	3V(rms) AM Modulated 1000Hz, 80%	B	B	PASS
Input/ Output DC. Power Port	0.15 –80 MHZ	3V(rms) AM Modulated 1000Hz, 80%	N/A	N/A	N/A
Signal Line	0.15 –80 MHZ	3V(rms) AM Modulated 1000Hz, 80%	N/A	N/A	N/A

Note: 1) N/A - denotes test is not applicable in this test report.

For the acoustic level of the demodulated audio limits

Frequency(MHz)	dB(SPL)
0,15 to 30	55
30 to 80	65



Note: According to EN 55035: 2017, Annex A, A.2 Applicability, the EUT belongs to Group 2. And then according to EN 55035: 2017, Annex A, A.4 Modified test levels and performance criteria, Table A.2 – Modified test levels for performance criterion A for the broadcast reception function, no test requirements apply to this EUT.

4.8 POWER FREQUENCY MAGNETIC FIELD TESTING

4.8.1 TEST SPECIFICATION

Basic Standard:	IEC/EN 61000-4-8
Required Performance:	B
Frequency Range:	50Hz
Field Strength:	1 A/m
Observation Time:	1 minute
Inductance Coil:	Rectangular type, 1mx1m

4.8.2 TEST PROCEDURE

The EUT and support equipment, are placed on a table that is 0.8 meter&0.1 meter above a metal ground plane measured 1m*1m min.

The other condition need as following manners:

- a. The equipment cabinets shall be connected to the safety earth directly on the GRP via the earth terminal of the EUT.
- b. The cables supplied or recommended by the equipment manufacturer shall be used. 1 meter of all cables used shall be exposed to the magnetic field.

4.8.3 TEST SETUP

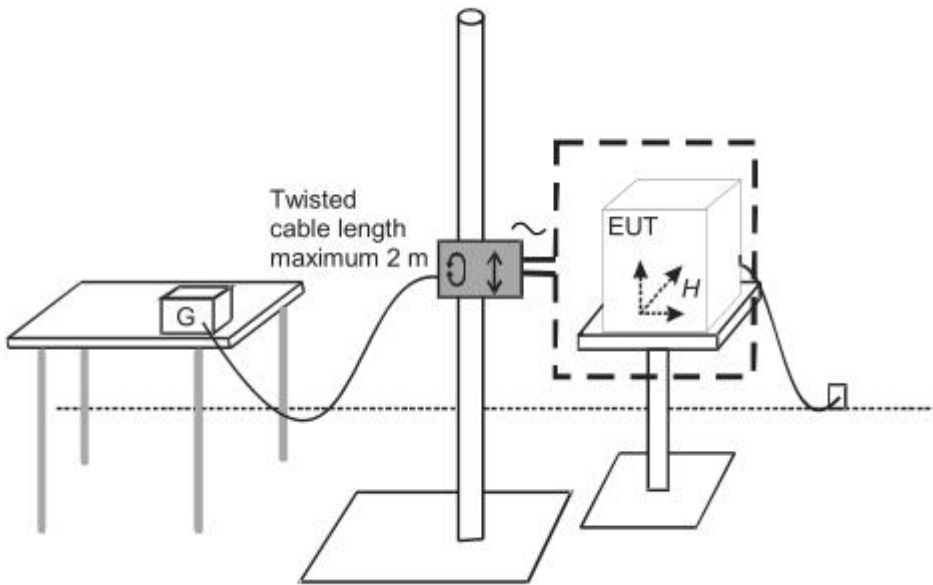

Note:

TABLE-TOP EQUIPMENT

The equipment shall be subjected to the test magnetic field by using the induction coil of standard dimension (1 m x 1 m). The induction coil shall then be rotated by 90 degrees in order to expose the EUT to the test field with different orientations.

FLOOR-STANDING EQUIPMENT

The equipment shall be subjected to the test magnetic field by using induction coils of suitable dimensions. The test shall be repeated by moving and shifting the induction coils, in order to test the whole volume of the EUT for each orthogonal direction. The test shall be repeated with the coil shifted to different positions along the side of the EUT, in steps corresponding to 50 % of the shortest side of the coil. The induction coil shall then be rotated by 90 degrees in order to expose the EUT to the test field with different orientations.



4.8.4 TEST RESULTS

Temperature:	23.9°C	Relative Humidity:	54%
Test Voltage:	AC 230V	Test Mode:	Mode1

Test Mode	Test Level	inductive coil	Duration (s)	Perform Criteria	Results	Judgment
Enclosure	3A/m	X	60s	B	B	PASS
Enclosure	3A/m	Y	60s	B	B	PASS
Enclosure	3A/m	Z	60s	B	B	PASS

4.9 VOLTAGE INTERRUPTION/DIPS TESTING (DIPS)

4.9.1 TEST SPECIFICATION

Basic Standard:	IEC/EN 61000-4-11
Required Performance:	B (For 100% Voltage Dips, 0.5 Cycle) B (For 100% Voltage Dips, 1 Cycle) C (For 30% Voltage Dips, 25 Cycles) C (For 100% Voltage Interruptions, 250 Cycles)
Test Duration Time:	Minimum three test events in sequence
Interval between Event:	Minimum ten seconds
Phase Angle:	0°/45°/90°/135°/180°/225°/270°/315°/360°
Test Cycle:	3 times

4.9.2 TEST PROCEDURE

The EUT shall be tested for each selected combination of test levels and duration with a sequence of three dips/interruptions with intervals of 10 s minimum (between each test event). Each representative mode of operation shall be tested. Abrupt changes in supply voltage shall occur at zero crossings of the voltage waveform.

4.9.3 TEST SETUP

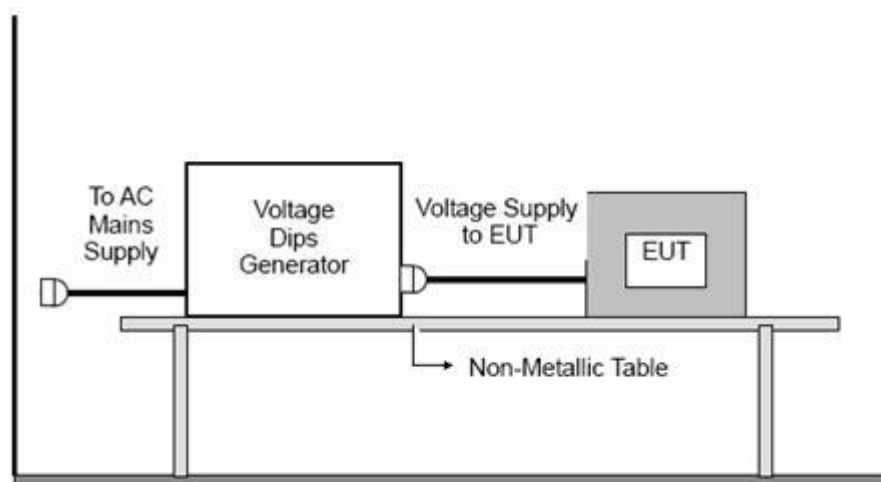



4.9.4 TEST RESULTS

Temperature:	23.9°C	Relative Humidity:	54%
Test Voltage:	AC 230V	Test Mode:	Mode1

Voltage Reduction	Duration (cycle)	Perform Criteria	Results	Judgment
Voltage dip 100%	0.5	B	B	PASS
Voltage dip 100%	1	B	B	PASS
Voltage dip 30%	25	C	B	PASS
Voltage interruptions	250	C	B	PASS

APPENDIX 1- TEST SETUP

RE

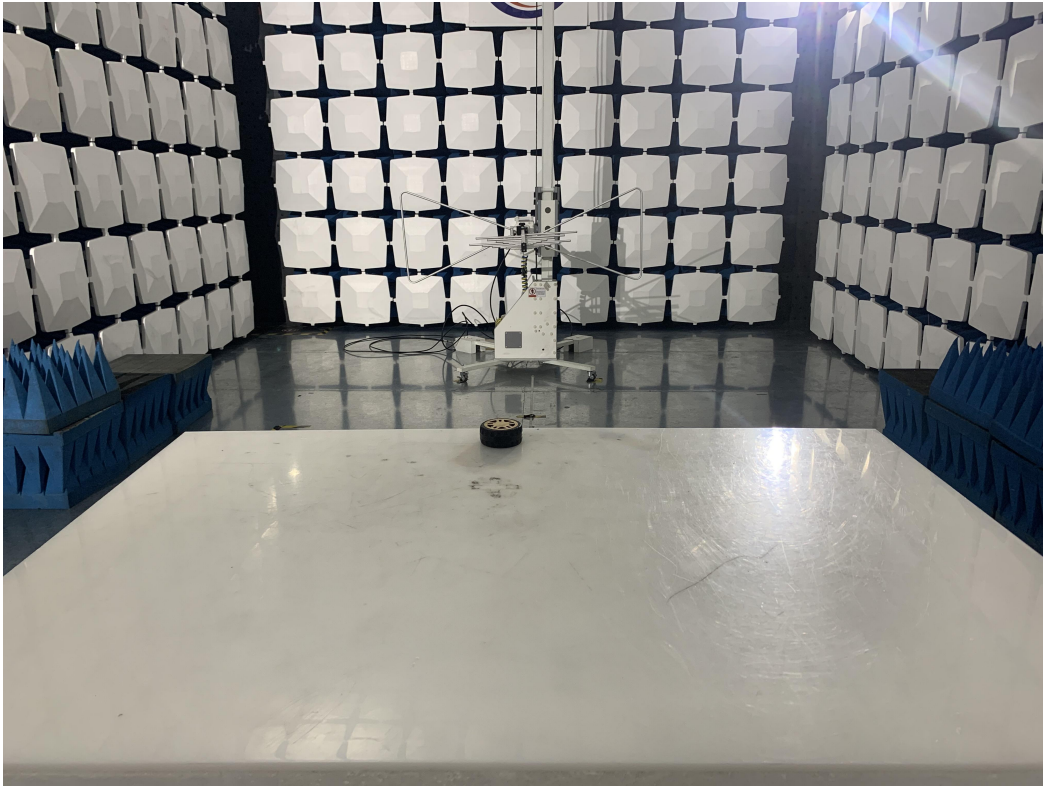

CE



ESD



※※※※※END OF THE REPORT※※※※※